

CONNECT

Address: Room 1903, Building A, 95 International Business Center,
JiangNan Road, No. 598, NingBo, China

Mobile Phone: 0086-13429251057

TEL: 0086-574-87475586 88362797

FAX: 0086-574-87474989

E-mail: sales@connectpoultry.com

CONNECT

CONNECT GROUP FOR POULTRY

Exclusive Turnkey Poultry Project Provider

Advanced poultry equipment manufacture

CONTANTS

POULTRY PROCESSING EQUIPMENT	/ 01
RENDERING EQUIPMENT	/ 31
BROILER FARMING EQUIPMENT	/ 51
INCUBATION EQUIPMENT	/ 65
POULTRY FEED PROCESSING EQUIPMENT	/ 81
STEEL FABRICATED HOUSE	/ 82
FREEZING EQUIPMENT	/ 83
CATTLE&SHEEP SLAUGHTERING EQUIPMENT	/ 84

VISION

In the more competition and fast poultry business growing conditions from worldwide, how to keep the leading position in poultry project builders, CONNECT firmly following the four optics:

Clear mission

To consider for customers, maximum do what ever clients request. build high quality project and try best to save investment for clients. With great supporting on technical and project civil work guiding ,and after service.

Constant innovation spirit

Keeping the great competition of products, we take technical Innovation as our company spirit, which consider from animal welfare, healthy, environmental protection and energy saving.

Modestly to learn advanced technology.

Integrity management With heart and assurance service, to communicate and coordinate with customers All for customers to solve any problem with first action. Regular project investigation and engineer re-checking of project after running

Team Work

Keeping the work team in great union ,active, Harmonious. Team work is the core concentric for corporate culture, company and individual create a better future with unity, Cooperation and hard working of all the staff.



To CONNECT customers' needs in providing packing solution for Poultry, Meat industries"

CONNECT is the exclusive turnkey poultry project provider in China to build advanced poultry processing plant, rendering plant, meat and farming industries for poultry and live stock. Our brand - CONNECT is widely used and accepted by the worldwide clients. We supply the turnkey project to meet our customers' complete project need. All products are manufactured according to EU. Standard, and highest world quality standards

CONNECT has five major manufacturing base in China, the agent and distributors are spreading many countries of worldwide. We working together to build excellently projects with high quality equipment and supply best-after sale services to all customers.

CONNECT group introduce a unique houses for raising different types of chicken from broilers, breeders, layers, in a turn-keys project including building and all machines with cages with maximum guarantee time ,with also availability to manage all the projects.

Other packing solution such as Chicken ,egg handling, meat deeply processing systems help you to establish real high quality, turn key project for Farm business.

CONNECT Poultry And Meat World:

A: Poultry Raising

Complete turn key project including building, equipment, electricity, water supply, sewage for complete closed house

For : Broilers-----Raising on ground, on net, in cage with complete equipment.

Breeder-----Pullets and Breeder raising equipment

Layers-----Pullets and layers in Cages with different raising amount in one house, with complete drinking, feeding, egg collection, manure cleaning system.

Grand mother and farther----- With different raising amount.

Incubator-----Single-stage incubator, from thousands eggs to twelve thousands eggs with all automatic control. Multi stage incubator which capacity is ninety thousands eggs.

With automatic tray and chicks processing system, including chicks sorting, ID, counting and packing, egg shell smash, egg washer, ventilation system of hatchery room.

Feed mill----- We cooperate with largest Chinese feed mill manufacture to supply best quality feed mill

Generator-----We cooperate with best Chinese manufacture to supply the back-up power for chicken farm

B. Poultry Processing

Complete turn-key project including building and all processing equipment. Including the below items:

Slaughterhouse---Full automatic and semi-automatic with different capacities, from 500BPH to 12000BPH

Cold room ---- Blast freezer, cold room, freezing tunnel, and Spiral Freezer for slaughterhouse

Rendering plant—slaughterhouse waste including feather, viscera, dead chicken protein recycling system

Waste water-----Slaughterhouse waste water treatment system

Meat processing—Bowl cutter, mixer, tumbler, frying, injection, packing...etc. all type of equipment.

C. Animal Processing

Complete turnkey animal processing line with building and equipment.



CONNECT IS EXCLUSIVE PROVIDE POULTRY TURNKEY PROJECT FROM PROJECT FEASIBILITY STUDY TO WHOLE PROJECT MANAGEMENT.

Including :



Breeder raising



Hatching



Broiler Ground raising system



Cage Raising system



Poultry processing



Feed mill



Fridge



Building



Rendering



Animal Processing

OUR MANUFACTURING EQUIPMENT

The quality of product is not only depends on device, but also depends on the strict process management. With advanced laser cutting machines, and R&D, mould processing, plastic injection system, we manufactured high quality central controlled production strictly follows international management certification.

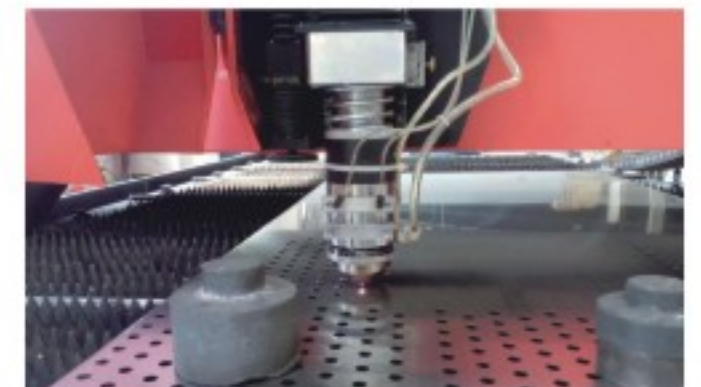

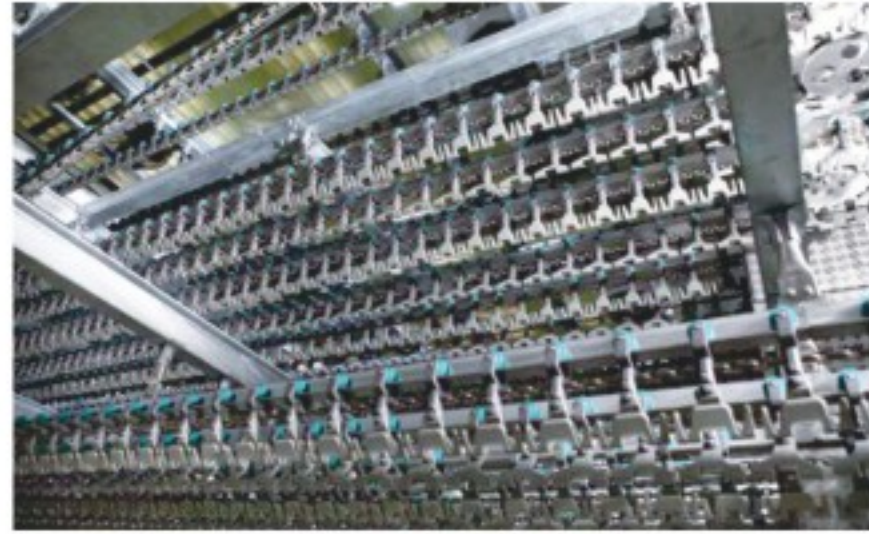

FULL AUTOMATIC POULTRY PROCESSING

EQUIPMENT WITH HIGH LATEST TECHNOLOGY



Crates Conveyor

» Crates belt conveyor

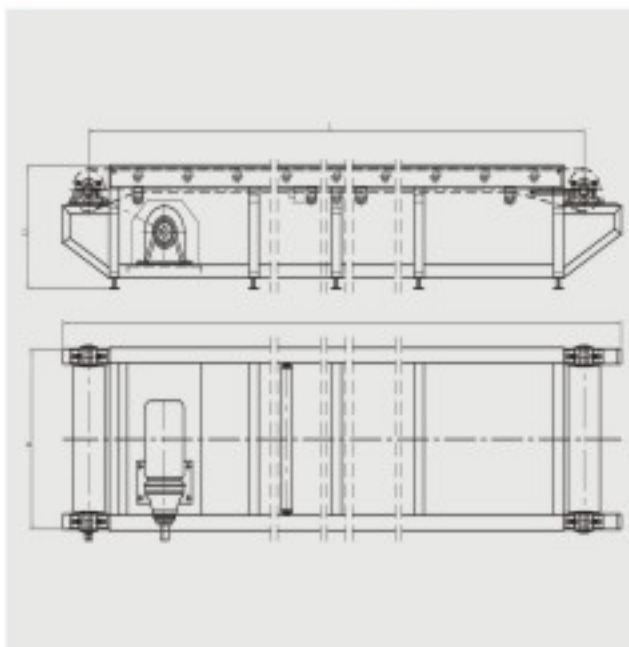

CONNECT crates conveying system with full industry experience and technology, All the crates conveyor manufactured with high quality stainless steel and industry grade belt system, quality guaranteed driving system, and installed in perfect mechanical structures. The system is easy for clients installation, high performance, belt is corrosion resistance, perfect furnish, with long service life. The farm of conveyor all manufactured with stainless steel, the belt with supporting rollers which specification is $\phi 60 \times 3$ stainless steel pipe, the belt is industrial grade corrosion resistance. The commissioning system is motor reducer which power is 0.75kw.

» Model:

SQ.	Model	Specification(mm)	Capacity(BPH)	Power (KW)
1	CBC-3000	3000 x 800 x 550	500	0.75
2	CBC-4000	4000 x 800 x 550	1000-1500	1.5
3	CBC-5000	5000 x 800 x 550	1500-2000	1.5
4	CBC-6000	6000 x 800 x 550	2000-4000	1.5
5	CBC-8000	8000 x 800 x 550	5000	1.5
6	CBC-9000	9000 x 800 x 550	6000	2.2
7	CBC-10000	10000 x 800 x 550	Above 8000	+2.2

» Rolling conveyor



CONNECT rolling type crates conveyor is designed with advanced technology and efficient practice working result. The full equipment manufactured with high quality stainless steel, long working life. The crates is forwarded driven by rolling rollers. With gear motor power system. Variety of size and model to meet different producing capacity of poultry slaughtering line.

» Model:

SQ.	Model	Specification(mm)	Capacity(BPH)	Power (KW)
1	CBC-3000	3000 x 800 x 550	500	0.75
2	CBC-4000	4000 x 800 x 550	1000-1500	1.5
3	CBC-5000	5000 x 800 x 550	1500-2000	1.5
4	CBC-6000	6000 x 800 x 550	2000-4000	1.5
5	CBC-8000	8000 x 800 x 550	5000	1.5
6	CBC-9000	9000 x 800 x 550	6000	2.2
7	CBC-10000	10000 x 800 x 550	Above 8000	+2.2

»» POM Chain conveyor



CONNECT POM chain conveyor working principle is same as belt conveyor. The whole system with full industry technology and reasonable structure, manufactured with high quality stainless steel and industrial POM chain.

During working, the chain moving forward with the driving system, at the same, the crates which above on is conveying forwarded together with POM chain. The system is easy for installation, efficiency working capacity, perfect in furnishing, with working life.

The frame of equipment is all made of stainless steel, with POM plastic chain to convey the crates, the chain is driven by gear motor system. Different models of conveyor to meet different production capacity.

»» Model:

SQ.	Model	Specification(mm)	Capacity(BPH)	Power (KW)
1	CBC-3000	3000 x 800 x 550	500	0.75
2	CBC-4000	4000 x 800 x 550	1000-1500	1.5
3	CBC-5000	5000 x 800 x 550	1500-2000	1.5
4	CBC-6000	6000 x 800 x 550	2000-4000	1.5
5	CBC-8000	8000 x 800 x 550	5000	1.5
6	CBC-9000	9000 x 800 x 550	6000	2.2
7	CBC-10000	10000 x 800 x 550	Above 8000	+2.2

Crates Washer

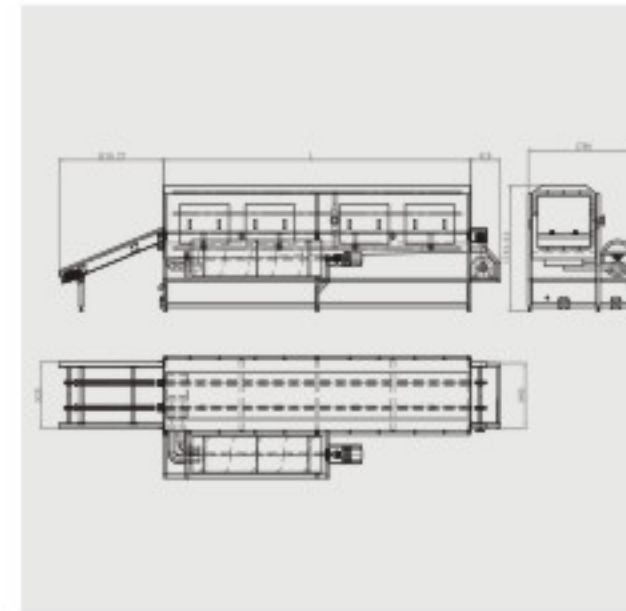

CONNECT crates washer is used for a special equipment which used for cleaning the live birding transportation crates, it is one of must used equipment for large scale slaughterhouse. Our crates washer is simple in structure, reasonable, operation stable, low working problem happens and easy maintenance. The whole system is combined with frame, transmission system, driving chain, spraying system, and water filter device. The working speed is adjustable. The system working together with crates conveying system which greatly rise the automatic level, and reduce the labors' working.

The equipment is driven by the motor which through the driving chain wheel realize the working to chain.

The crate washer connected with the conveyor conveyor which transport the crates into washer. The inside washer equipped with spraying nozzle.. The spraying device including two stages, which is washing and disinfection.

The water which after washing including some feature and dirt goes into filter system, and get the clean water which collection in the water collecting tank; The water recycling system for disinfection stage is same as wash stage. There is one block between the cleaning water and disinfection water.

»» Model:

SQ.	Model	Specification(mm)	Capacity(BPH)	Pump Power (KW)	Steam consumption (kg/H)	Water consumption (liter/H)
1	CW-2000	3200 x 1700 x 1800	500-2000	3.5	100	500-1000
2	CW-4000	5200 x 1700 x 1800	2000-5000	4.0	200	500-1000
3	CW-4400	5600 x 1700 x 1800	5000	4.5	200	500-1000
4	CW-6000	7500 x 1700 x 1800	5000-10000	5.0	200	500-1000
5	CW-8000	7500 x 1700 x 1800	10000-12000	5.5	200	500-1000

Crates stack & De-stack machine

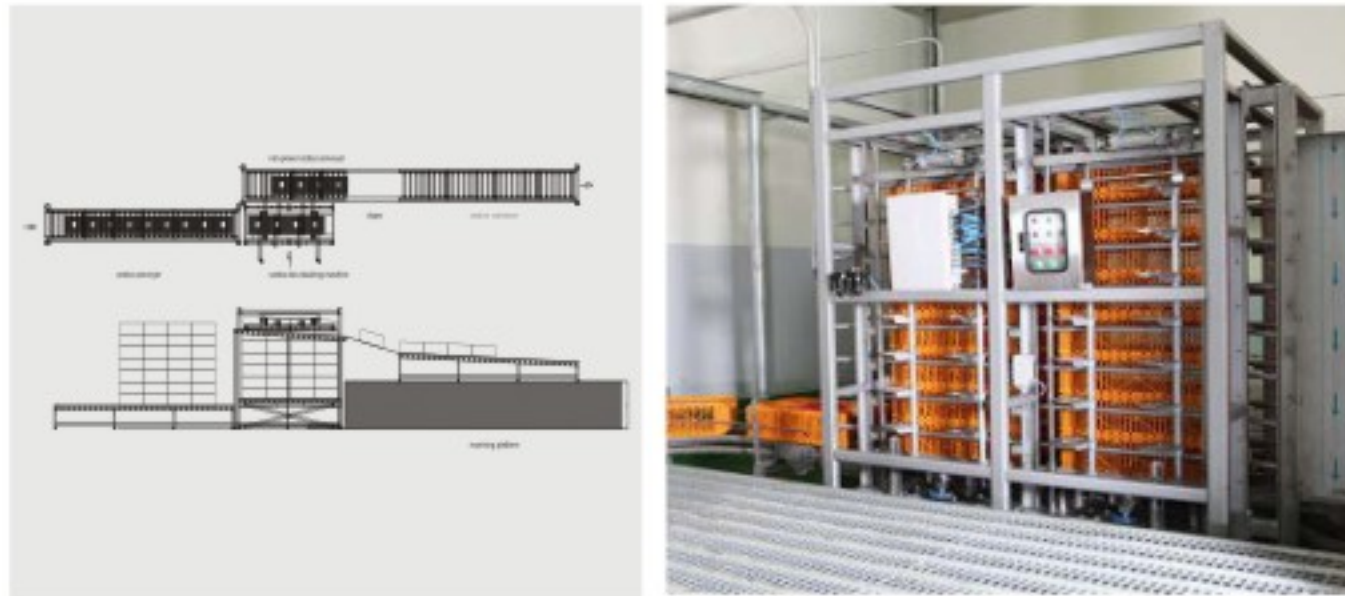

Crates Stack and de-stack system is designed for automatic working of slaughterhouse which capacity from 10,000 to 12,000BPH, easy load from chicken farm, loading off from trucks, weighing and reception of slaughterhouse work. Reduce the labor, focus on the efficient work, realize the economic operation of slaughterhouse.

Capacity: 21 crates/Minutes

The conveyor is driving by nylon chain, hydraulic motor, speed is 36 meter/Minute

Motor power: 22kw, imported hydraulic oil pump, and accessories

PLC control system with Omron and other imported appliance.



Stunner

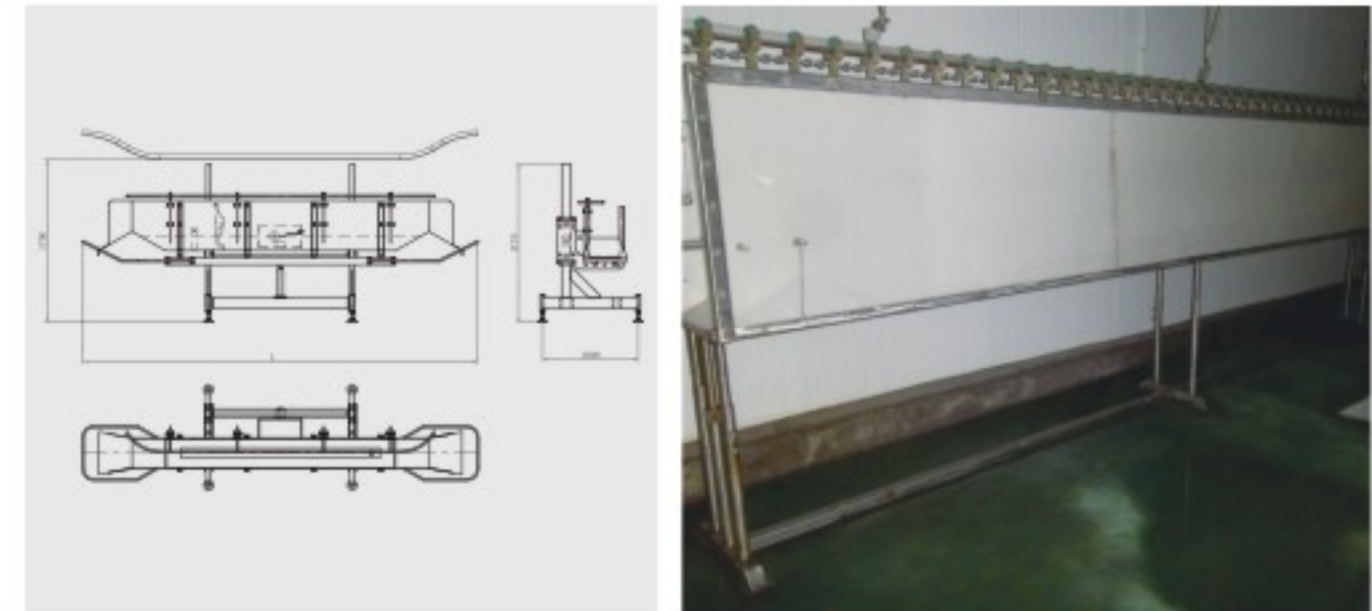

CONNECT RMC series stunner power core is microprocessor, with MPWM, active component IGBT module design, digital frequency conversion, D/A, instantaneous feedback, sinusoids sor, with pulse width modulation technology, the single machine capacity reach to 400KVA, to isolate the transformer output and increase the stability of the complete machine.

The stunner has the characteristics of strong load adaptability, output waveform is good quality, simple operation, small volume, light weight, also with short circuit, over current, overload, overheating protection to ensure reliable power operation.

Model:

SQ.	Model	Volt (V)	Hertz	Dimension(mm)	Shock time(s)
1	GSDM-I-2000	0-110	0-999	2120x1000*1700	8
2	GSDM-I-4000	0-110	0-999	4120x1000*1700	8
3	GSDM-I-6000	0-110	0-999	6120x1000*1700	8
4	SDM-11	0-110	0-50	2120x1000x1700	8

Scalder

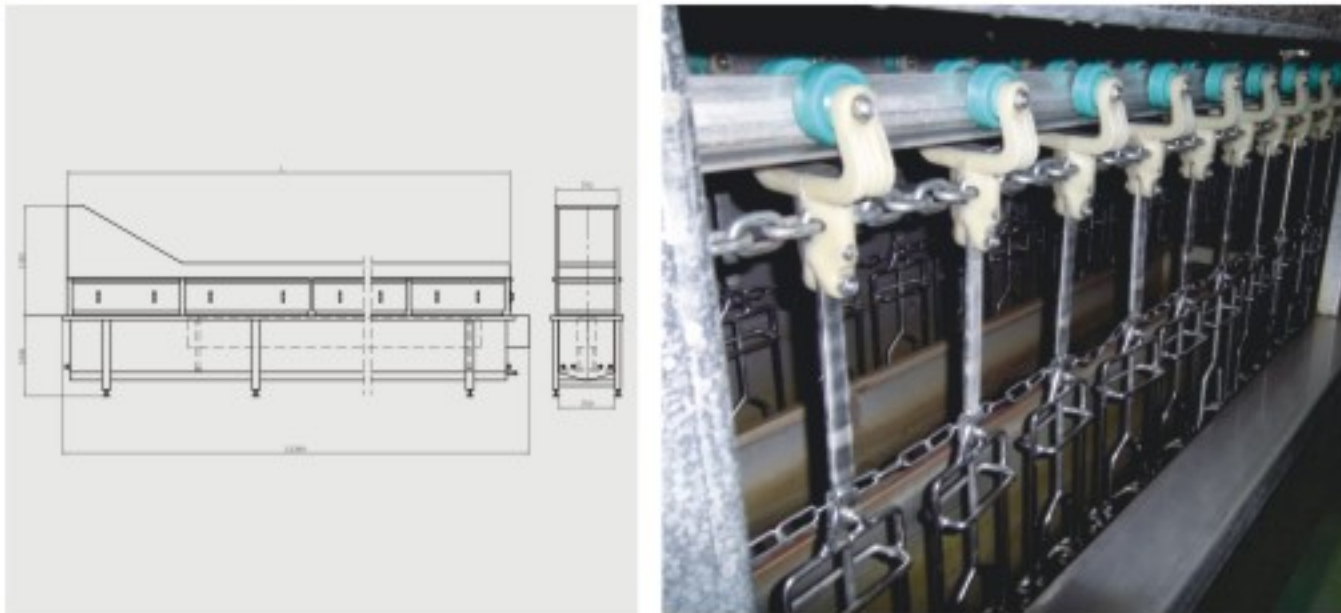

Scalding plays an important role in the whole processing, the good scalding raise the defeathering rate, save labors' working, reducing damage rate and increase the profit. Working with CONNECT scalder, the feathers is easy operation, simple structure, low power, maintenance rate very low. The whole equipment is closed system which reducing the heat lose. The equipment including tank body, heating supply system, over head conveyor, automatic temperature control, automatic water supply, and closed cover. The air blowing system including blower, air pipes.

CONNECT scalding temperature is from 58 to 61 °C, the scalding time is from 60 to 90 seconds which is adjustable according to the combination factors of processing line.

CONNECT have variety of scalder to meet different capacity of poultry processing system work.

»» Model:

SQ.	Model	Specification (mm)	Working pressure (Mpa)	Steam consumption (KG/H)	Water consumption (liter/bird)	No. of Pass
1	JS-2400	2400 x 700 x 2200	0.4	100-200	0.25	2
2	JS-4000	4000 x 700 x 2200	0.4	100-200	0.25	2
3	JS-6000	6000 x 700 x 2200	0.4	500-1000	0.25	2
4	JS-8000	8000 x 700 x 2200	0.4	500-1000	0.25	2
5	JS-10000	10000 x 700 x 2200	0.4	500-1000	0.25	2
6	JS-12000	12000 x 700 x 2200	0.4	500-1000	0.25	2
7	JS-14000	14000 x 700 x 2200	0.4	500-1000	0.25	2
8	JS-.....	... x 1100x2200	0.4	500-1000	0.25	3

Chicken Automatic Plucking Machine



There are two kinds of plucker which are rough plucker and fine plucker. Connect plucker is the latest and development of next-generation products based on the merits of the old models. The performance indicator reach to a new level by its features of more beautifully in appearance, structure and material used is more rational, more easily in adjusting.

»» Features:

1. By using the electric system adjusts the position of plucking cabinet, which is easy operation.
2. Avoiding the old model plucker adjusting system lock.
3. It is fast adjusted to the last shift operating position after cleaning.
4. The open and close system is symmetrical on both sides simultaneously adjusted, flexible in operation.
5. The height of fours legs can be adjusted individually.
6. Waterproof of bearing is more reasonable and reliable.
7. Drum pulley is smoothly and reliable in operation.
8. Easier to clean and repair.

»» Model:

SQ.	Model	No. of rows	Discs. Qty./row	Rubber Finger Qty	Motor power (kw)
1	RP-24	4	6	240	1.5 X 4
2	RP-32	4	8	320	2.2 X 4
3	RP-40	4	10	400	2.2 X 4
4	RP-64	4	16	640	2.2 X 8
5	FP-36	6	6	288	1.5 X 6
6	FP-48	6	8	384	2.2 X 6
7	FP-60	6	10	480	2.2 X 6
8	FP-96	6	16	768	2.2 X 12

Automatic Feet cutter

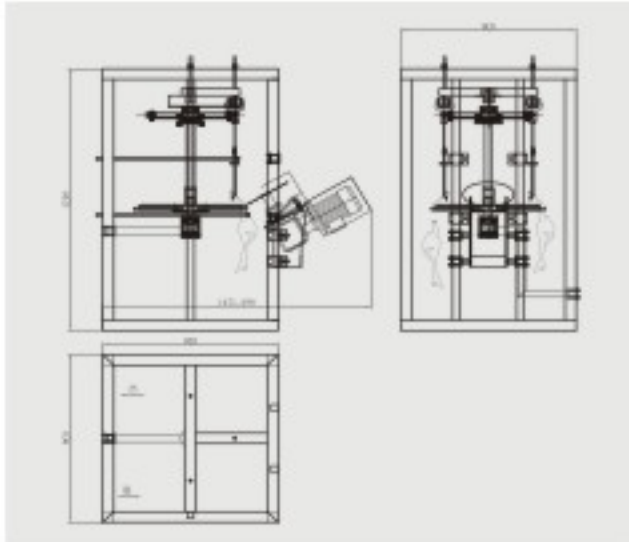

The CONNECT Automatic Feet Cutter is a field proven technique of cutting hocks on broilers as well as hens. Due to the simple design of few moving parts, you can expect the Connect Feet Cutter to give you continuous day-in, Day-out precision cutting performance. By use of a specially designed chain, the feet cutter automatically positions and severs the hock joint by nicking, disjuncting and cutting the joint completely off or to the last tendon for auto re-hanging.

Automatic Feet unloader

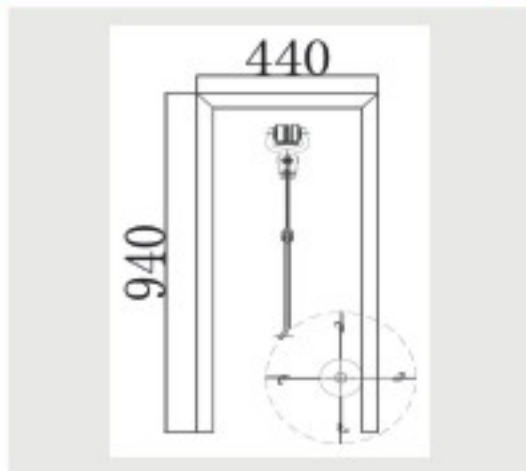

During the poultry processing equipment working, the chicken after slaughtered, removing the feature, cut the feet, the carcass body goes to the next processing stage, but the feet have to remove from the shackles, which need to further processing by removing its yellow skin, and put into cold room. The feet automatically unloading from the overhead conveyor line when the line pass the feet unloader to realize the fully automatic working.

Specification of main parameter data:

Dimension: 2000 x 550 x 958mm

Working capacity: 1000-12000BPH

Motor power: 0.37kw

Rotating drum rmp: 70rmp

Automatic Head cutter

CONNECT head cutter is to cut the chicken head automatically on conveyor line to reduce the labor worker, raise the working efficiency. The structure is reasonable. Good in performance, the height of equipment can be adjusted freely.

The main specification:

Length: 980mm

Height: 1650mm

Width: 620mm

Power: 0.75kw

The working principle

The head cutter is all made of stainless steel, combined with height adjustable rack, regulated guiding bar, driving unit, and cutter. The chicken head goes to the guiding bar working area with the forwarding of conveyor line, the guiding bar gradually become narrow until to 20mm, the chicken head is pulled to down location with the guiding bar working, and the chicken head is pulled cut, but the skin of chicken neck still connected, with the blade cutter which clockwise rotating cut the head completely, the chicken goes to collection tank or pumping to waste collection.

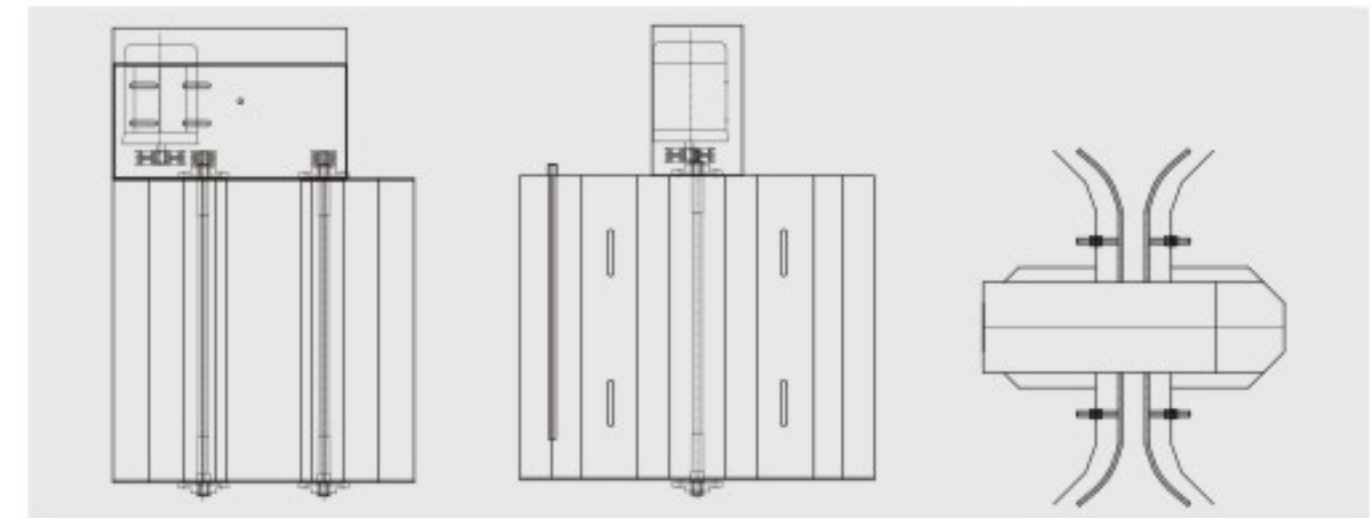

The CONNECT Shackle Washer is designed to automatically clean and sanitize the conveyor shackles, hangers and ties without manual labor. Adjustments can be made to clean the chain and trolleys as well. The two motor-driven nylon brushes and inside water jets carefully clean all surfaces that pass between the brushes. The driving motor power is 0.37kw.

Re-Hanging Machine



More than 99% of re-hanging rate is possible by the precise control with encoder method
 In case of momentary load, re-hanging is executed at the original site
 In case of the mechanical load occurrence, the cylinder operates and drops the carcass automated ally in order to prevent fracture of the leg. When the machine is self-restored, the cylinder stops operation
 As re-hanging is executed by the clip-typed lever method using the spring rather than the lever of given interval, re-hanging is possible without any fracture of leg though the chicken size is different
 The blade of the chicken-leg cutter is made of 440C material which is excellent in durability
 10 Units
 Length : 2200mm
 Width : 2200mm
 Height : 2700mm
 Weight : 870kg

Vent cutter



There is no operational error as the probe pole is set at the same work standard point all the time in proportion to the size of carcass from broiler chicken to layer chicken
 By cutting after pulling back the tail, accurate and hygienic work is possible without damage of the tail part
 After cutting the vent accurately with the rotating circular blade, the machine draws up the vent by about 5-6cm and makes it hung outside the carcass
 The circular blade for cutting vent is excellent in durability as it is made of the high speed steel which is low in wear rate and special-heat treated
 The blade is easy to replace as it is screw driven
 The circular blade passes through the washing section once after the vent operation is completed in order to prevent cross-contamination in the next processing
 The New vent cutter is an extremely-advanced machine. Its characteristics are:
 Productivity up to 12,000 Bph
 Machine self-adjusting in case of different bird size
 Regular cut on different bird size
 Only vent cut
 Operators high safety standard
 Highly reliable
 High hygiene standard
 Easy cleaning
 Total reduction of hardly-washable surfaces

»» Model:

SQ.	Capacity (bph)	3000	6000	10000	4000	10000
1	Live bird weight (kg)	1.2-3.5	1.2-3.5	1.2-3.5	1.2-3.5	1.2-3.5
2	Unit number	7	14	20	14	20
3	Shackle pitch (Inch)	6"	6"	6"	8"	8"
4	Machine Dimension L(mm)	1550	1750	1750	1550	1750
5	Machine Dimension W (mm)	1297	1297	1297	1297	1297
6	Machine Height H (mm)	2600	2600	2600	2600	2600
7	Weight (kg)	650	750	850	650	850
8	Water	Connection(Inch)	½"	½"	½"	½"
		Consumption (m³/H)	0.6	0.6	0.6	0.6
		Outlet (mm)	DN100	DN100	DN100	DN100

Opener



Vent Opener is capable of bypass, upper and lower operation, and adjustment as the occasion demands

All the materials, by using stainless steel and special material, are excellent in durability

When opening the vent, a spherical ball is attached to the blade fixing device in order to prevent damage of the viscera in the carcass, avoiding the contamination of carcass caused by breakage of the viscera

By adjusting the stroke of blade operation with the CAM, the machine controls the cutting depth, cutting length, etc., letting adjustment possible according to various weight and carcass size of ginseng chicken, broiler chicken, layer chicken (old chicken) etc

The New vent Opener is an extremely-advanced machine. Its characteristics are:

Productivity up to 12,000 Bph

Machine self-adjusting in case of different bird size

Regular cut on different bird size

Only vent cut

Operators high safety standard

Highly reliable

High hygiene standard

Easy cleaning

Total reduction of hardly-washable surfaces

»» Model:

SQ.	Capacity (bph)	3000	6000	10000	4000	10000
1	Live bird weight (kg)	1.2-3.5	1.2-3.5	1.2-3.5	1.2-3.5	1.2-3.5
2	Unit number		14	20	12	20
3	Shackle pitch (Inch)		6"	6"	8"	8"
4	Machine Dimension L(mm)		1705	1705	1705	1705
5	Machine Dimension W (mm)		1382	1382	1382	1382
6	Machine Height H (mm)		2600	2600	2600	2600
7	Weight (kg)		600	650	600	650
8	Water	Connection(Inch)	½"	½"	½"	½"
		Consumption (m³/H)	0.1	0.1	0.1	0.1
		Outlet (mm)	DN100	DN100	DN100	DN100

Eviscerator



This eviscerator has been developed to be suitable for the characteristics of the chicken produced in each country, having large adaptability according to the deviation of chicken

It does not damage the viscera even at a high speed of 12,500 chickens per hour, and picks up the neck accurately at the bottom point of neck guide, extracting the viscera very stably

The real-time monitor of the clip-typed eviscerator indicates the hourly treatment speed, quantity of chicken and viscera, evisceration rate, and evisceration rate per each unit, making management of carcass quality and machine very easy

The clip-typed spoon of the eviscerator is washed by the injection nozzle after the operation is completed, and then returns to the initial processing

The viscera extracted without damage are automated ally transferred to the pack shackle of the viscera processing line, and all the facilities of the viscera processing line can be automated, leading to the labor cuts

The visceral residue generated during the evisceration work is gathered at the collect tank beneath the lower hopper, and is transferred and collected at a certain place by the transfer device

»» Model:

SQ.	Capacity (bph)	3000	6000	10000	4000	10000
1	Live bird weight (kg)	1.2-3.5	1.2-3.5	1.2-3.5	1.2-3.5	1.2-3.5
2	Unit number	12	24	28		24
3	Shackle pitch (Inch)	6"	6"	6"		8"
4	Machine Dimension L(mm)	3100	3100	3100		3100
5	Machine Dimension W (mm)	2400	2400	2400		2400
6	Machine Height H (mm)	2800	2800	2800		2800
7	Weight (kg)	2500	2800	3000		3000
8	Water	Connection(Inch)	½"	½"	½"	½"
		Consumption (m³/H)	2.5	2.5	2.5	2.5
		Outlet (mm)	DN100	DN100	DN100	DN100

Cropper



The crop-removing spindle passes through the abdominal cavity of carcass and rotates at the neck part, removing the respiratory tract, esophagus and crop effectively

The spindle rotates and winds the crop and the respiratory tract tube, which are separated and removed by the brush

As the washing water is sprayed to the inside of carcass, the washing effect of the carcass is outstanding

When the spindle is worn out, it can be easily replaced

Up-and-down operation by hydraulic pressure, adjustment and replacement of parts, and maintenance, such as bypass et al, are easy

All the materials, by selecting the stainless steel 304 and special material, are excellent in durability

» Model:

SQ.	Capacity (bph)	3000	6000	10000	4000	10000
1	Live bird weight (kg)	1.2-3.5	1.2-3.5	1.2-3.5	1.2-3.5	1.2-3.5
2	Unit number	8	16	20		24
3	Shackle pitch (Inch)	6"	6"	6"		8"
4	Machine Dimension L(mm)	1555	1555	1555		1555
5	Machine Dimension W (mm)	1290	1290	1290		1290
6	Machine Height H (mm)	1944	1944	1944		1944
7	Weight (kg)	810	860	900		900
8	Water	Connection(Inch)	½"	½"	½"	½"
		Consumption (m³/H)	2.5	2.5	2.5	2.5
		Outlet (mm)	DN100	DN100	DN100	DN100

Final inspection Machine



After entering into the internal part, the suction gun effectively removes the visceral residue remaining in the abdominal cavity, such as lung particle

Blood corpuscles et al, by strong vacuum pressure

The units having finished the vacuum suction are washed by the spray nozzle in order to prevent the cross contamination in the next work

The final inspector controls the vacuum suction rate easily and also has the bypass function, making part replacement and maintenance convenient

All the materials are stainless steel and especially durable material

As the vacuum is released once during the suction stroke in order not to constrain the carcass, the carcass is not damaged by the vacuum pressure

» Model:

SQ.	Capacity (bph)	3000	6000	10000	4000	10000
1	Live bird weight (kg)	1.2-3.5	1.2-3.5	1.2-3.5	1.2-3.5	1.2-3.5
2	Unit number	7	14	20	12	20
3	Shackle pitch (Inch)	6"	6"	6"	8"	8"
4	Machine Dimension L(mm)	1722	1722	1722	1722	1722
5	Machine Dimension W (mm)	1272	1272	1272	1272	1272
6	Machine Height H (mm)	12505	12505	12505	12505	12505
7	Weight (kg)	750	800	850	800	850

Inside & outside bird washer



The carcass washer controls the water capacity of external spray by independent valve method, and lets up-and-down stroke of the internal spray nozzle be controlled

As the washing probe at the end part of internal unit opens the space of the neck part, the washing water flushes well without damaging the carcass

As the washing water is sprayed out only when the spray nozzle goes up and down inside the carcass, water usage is minimized

The washing nozzles are installed at both inside and outside of the carcass, making it possible to wash both inside and outside at the same time

The washing capacity and pressure control are made easy, as well as the bypass, and adjustment, replacement and maintenance of components are convenient. Especially durable materials, such as stainless steel et al, were selected for all the materials

»» Model:

SQ.	Capacity (bph)	3000	6000	10000	4000	10000
1	Live bird weight (kg)	1.2-3.5	1.2-3.5	1.2-3.5	1.2-3.5	1.2-3.5
2	Unit number		14	20	12	20
3	Shackle pitch (Inch)		6"	6"	8"	8"
4	Machine Dimension L(mm)		1520	1520	1520	1520
5	Machine Dimension W (mm)		1315	1315	1315	1315
6	Machine Height H (mm)		2035	2035	2035	2035
7	Weight (kg)		585	650	585	650
8	Water	Connection(Inch)	½"	½"	½"	½"
		Outlet (mm)	DN100	DN100	DN100	DN100

Water Chiller

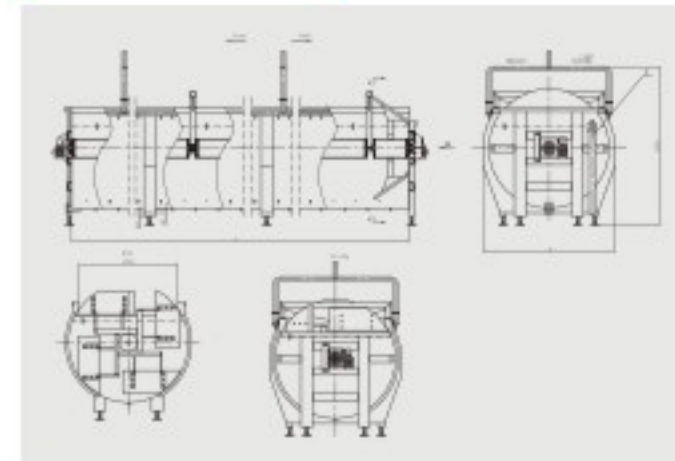

Function

Screw chiller is used for pre-chilling carcass or its by-products during the poultry process. Early 1990s, we first exclusively manufactured this machine after investigate many countries equipment. It win the highly evaluation by users after promotion in China. It have the following special feathers and benefits according to the traditional water tank pre-chilling.

- Small space needed.
- Saving energy by small amount of energy loss.
- Good pre-cooling effect; The traditional water tank pre-chilling which chicken just pass by the tank which hanging on the shackles with the conveyor line, the blood water and blood which in chest and skin is hard to remove out. But the chicken in screw chiller forward by screw blade pushing, and at the same time with the air blow up which by fans to make chicken turns around in the water, which make the blood move out from chest.
- All build by stainless steel, aesthetic, health, entirely up to international standards.
- The shaft rotating speed is regulated by converter, which effect control the chilling time.

The structure and working principle.

The screw chilling including two model, one is single-driver, the other is dual driver. The overall equipment including two section which one for washing, the other for chilling. It composed by semi-circular cylinder, screw blade, main shaft, dumper, and driving unit. The working process follow the principle of bird and water fowl reverse, which is after the water filled, the overflow exit is in front to best washing birds.

»» Model:

SQ.	Name	Tank Dia. Φ(mm)	Tank Dimension (mm)	Qty. of Driver	Power(kw)		Fan Power(kw)	Water loading Capacity(Ton)
					Shaft	Damper		
1	½ tube Screw chiller	1600	4000×1600×1900	1	0.37		2.2	4
2	½ tube Screw chiller	1600	6000×1600×1900	1	0.37		3.0	6
3	½ tube Screw chiller	1600	8000×1600×1900	1	0.37		5.5	8
4	½ tube Screw chiller	1600	10000×1600×1900	1	0.37		3.0*2	10
5	½ tube Screw chiller	1600	12000×1600×1900	1	0.55		4.0*2	12
6	½ tube Screw chiller	1600	14000×1600×1900	2	0.55	0.55	5.5*2	14
7	½ tube Screw chiller	1600	16000×1600×1900	2	0.55	0.55	4.0*3	16
8	½ tube Screw chiller	2100	4000×2100×2400	1	0.55	0.55	3.0	6.8
9	½ tube Screw chiller	2100	6000×2100×2400	2	0.55	0.55	5.5	10.2
10	½ tube Screw chiller	2100	8000×2100×2400	2	0.55	0.55	5.5	13.6
11	½ tube Screw chiller	2100	10000×2100×2400	2	0.55	0.55	3.0*2	17
12	½ tube Screw chiller	2100	12000×2100×2400	2	0.55	0.55	4.0*2	20.4
13	¼ tube screw chiller	1600	4000x1600x1900	2	0.55	0.55	3.0	7.6
14	¼ tube screw chiller	1600	6000x1600x1900	2	0.55	0.55	4.0	11.4
15	¼ tube screw chiller	1600	8000x1600x1900	2	0.75	0.75	5.5	15.2
16	¼ tube screw chiller	1600	10000x1600x1900	2	0.75	0.75	4.0*2	19
17	¼ tube screw chiller	1600	12000x1600x1900	2	0.75	0.75	5.5*2	30.4
18	¼ tube screw chiller	2100	6000x2100x2400	2	0.75	0.75	5.5	13.8
19	¼ tube screw chiller	2100	8000x2100x2400	2	0.75	0.75	5.5	18.4
20	¼ tube screw chiller	2100	10000x2100x2400	2	0.75	0.75	4.0*2	23
21	¼ tube screw chiller	2100	12000x2100x2400	2	0.75	0.75	5.5*2	27.6
22	¼ tube screw chiller	3050					

Air chilling



Air chilling at the second stage



Air chilling at side

In the case of other companies, water spraying throughout the whole interior of room causes the waste of chilling water, and frost formed on the heating surface of the unit cooler installed at the upper part lowers the chilling efficiency. However, Air chilling system, having improved these shortcomings, saves water as well as prevents the epidermis from getting dry, and lowers the relative humidity of the chilling chamber in order to maximize the energy-saving effect, by wetting only the required parts of both the inside and outside of the passing carcass fully in order to make the carcass absorb enough water with the installation of the shower box casing in the right places. In addition, by installing the chilling water shower, Air system pumps the fixed quantity of antiseptic solution, leading to increasing the chilling efficiency and restraining the reduction in quantity of the antiseptic solution, as well as the disinfection.

Bleeding Trough



The bleeding trough is the blood collecting system. The chicken blood drops down to the blood trough during the birds passing along with the overhead conveyor line. The blood trough size and shape design is according to the overhead conveyor arrangement of processing line. The trough is build with full stainless steel. The blood pumping system is equipment with trough which transfer the blood outside of slaughterhouse to the collecting tanks or rendering plant.

Weighing and Grading system



Production boxes conveyor at weighing line



Auto. Weighing line (Max.13,000BPH)

On line Weighing Grading system

Selecting up to 12,500 chickens per hour is possible

N:N function enables the same weight of chickens to be dropped from several places

The internet remote control enables technological assistance and updating

It is possible to drop the needed quantity in the required place

Dropping two kinds of weight from one cylinder is possible

Compensation of weight either wholly or individually is possible

While at work, cylinder switching and weight compensation can be operative

Chain sagging can be compensated by the sensor and program

Weekly and/or monthly management of production state by farm family and vehicle is possible

(optional)

When problem occurs at the shackle and weight sensor, error message displays

Weight and quantity by entity can be figured out and treated automated ally

Worked data can be figured out and printed by hour

Database and graphic processing et al can be freely set up in proportion to the weight the user requires and by the farm family

This system is effective in labor force reduction, hygiene improvement and output increase, and has the effect of saving investment cost when extending the facilities

»» Belt weighing & Grading System

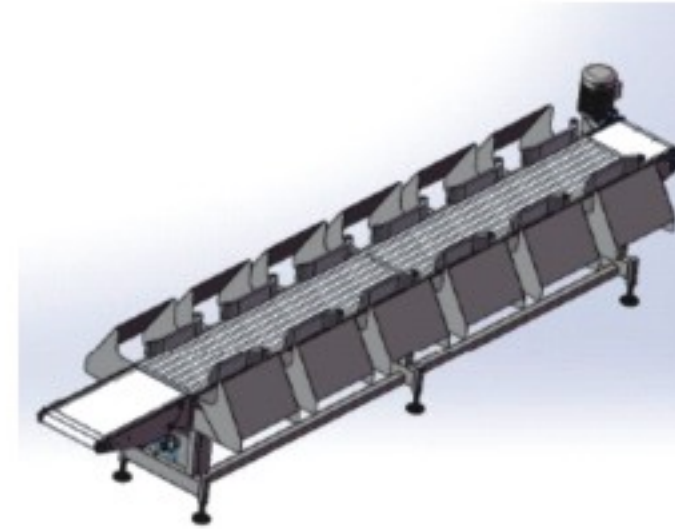

This machine is used at the poultry slaughterhouse to automatically weigh the poultry carcasses and grade, sort the weight of the poultry carcasses according to the customer' s request. The machine could stat and record the weight of each grade by itself, has a storage and memory function as well as could archive and retrieve the completed records.

The grading procedure only needs the manual feeding, other procedures are all automatically, it is very helpful for the poultry processing automation management.

This machine has four parts: Conveying Belt Conveyor, Weighing Belt Conveyor, Grading Belt Conveyor and Electric Control Cabinet. The Conveying Belt Conveyor conveys the poultry carcasses, Weighing Belt Conveyor complete the weighing function and transmit the data to the touch screen for the data processing and storage. The Electric Control Cabinet control all the conveyors and transmit the data as well as manage the procedures.

Cut-Up System

Along with change of the dietary life pattern and the development of fast food industry, consumption of the cut of meat is increasing gradually. The cut-up system is according to the changing trend of the processed food, provides our customers with the best system which can satisfy all of their requirements.



Tail cutter

Cutting the tail, unhygienic part, from the carcass



Throat cutter

Cutting the neck from the carcass



Wing cutter
Separating the wings from the carcass through two rotary blades

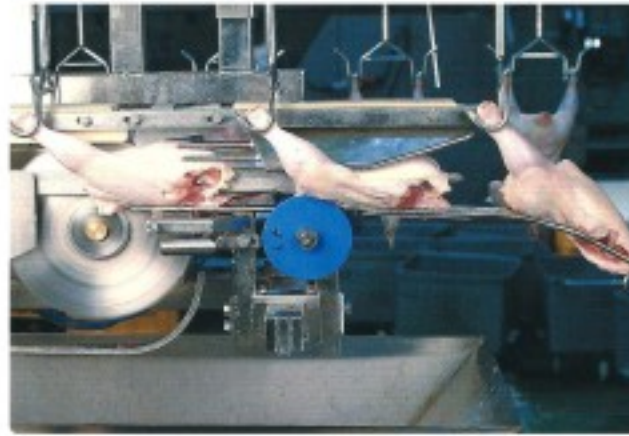

Longitudinal biangular cutter
The machine cutting the carcass in the longitudinal Direction

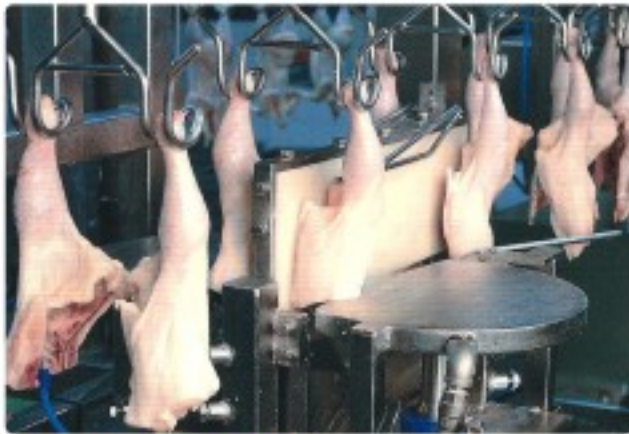

Horizontal biangular cutter
Generally the horizontal biangular cutter is the machine that cuts the trunk from breast to thigh, and it is possible to cut the carcass into four parts horizontally after the longitudinal cut processing by customers' demand and/or according to the work environment.



Thigh cutter
Thigh cutter is the machine cutting the thigh under the drum stick and the rotary blade cuts the joint.



Drum-stick dropper
Playing the role of dropping the drum stick from the shackle, as the final processing of cut-up system, after all of the cut processing have been finished



Mastodon bone cutter
Consisting of two rotary blades, with the first blade incising the skin between legs and breast and the second blade cutting subsequently the front part (the remaining part)

Gizzard processor

» Gizzard cutter

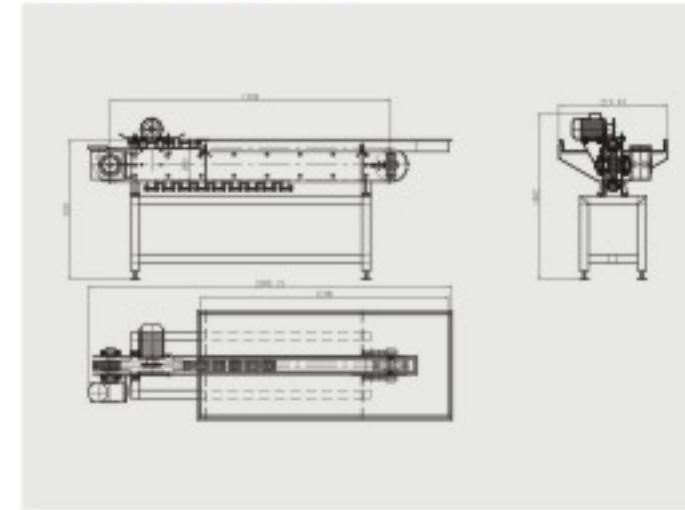

Capacity: 5000BPH



»» Gizzard de-fatter

Gizzard de-fatter is used to remove the fat from gizzards body. This de-fatter is simple in structure, easy operation, labor saving. It is formed with frame, driving unit, rotating bottom sheet and drum. The rubber fingers are installed on bottom sheet and inside drum body with the rotating of them ,the fat is removed. The capacity is reach up to 5000 BPH.

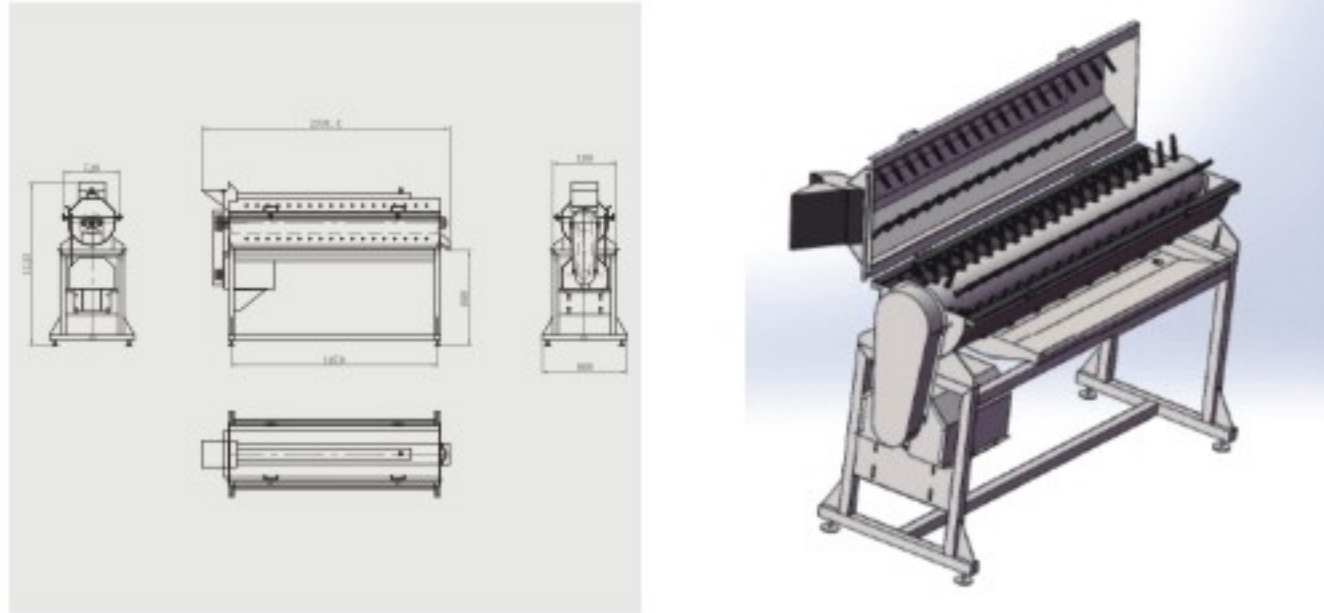

»» Gizzard Peeler

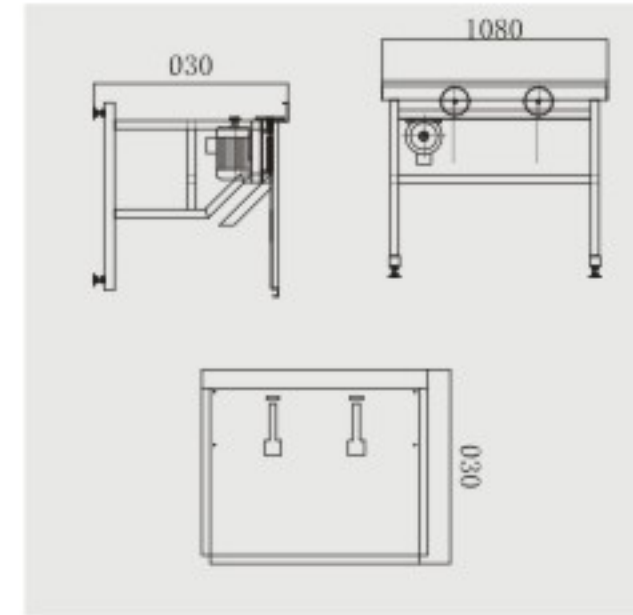

Gizzard peeler is the equipment to remove the membrane of gizzard. This machine is simple in its structure, easy operation, lower cost. The working function is that the two rolling shafts are driving by transmission system, and taken the membrane off. There are two models, one with one pair of peeling rollers, the other one with two pair of peeling rollers.

Chicken feet processing system

»» The capacity up to 1ton of chicken feet/H each line



»» By-products Spiral Chiller »» Feather , Offal & water separator



»» Belt conveyoy

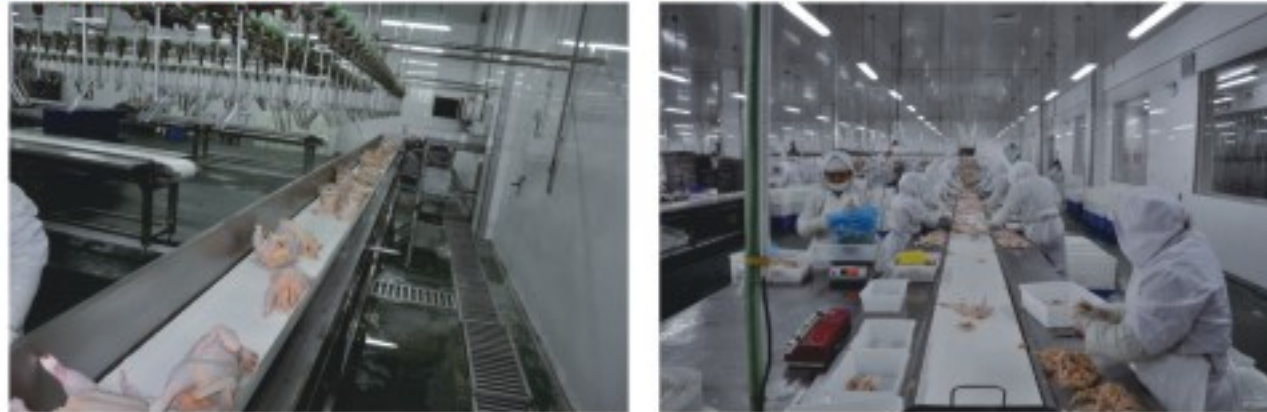

»» Freezing Cart

»» Freezing tray



»» Transporting trolley cart



»» Trolley bucket



»» Boot rack



»» Live bird crate



»» Plastic basket



»» Uniform rack



»» Birds transport belt



»» Compact system

From bird hanging to Evisceration, less installation area needs, capacity from 300 - 500BPH

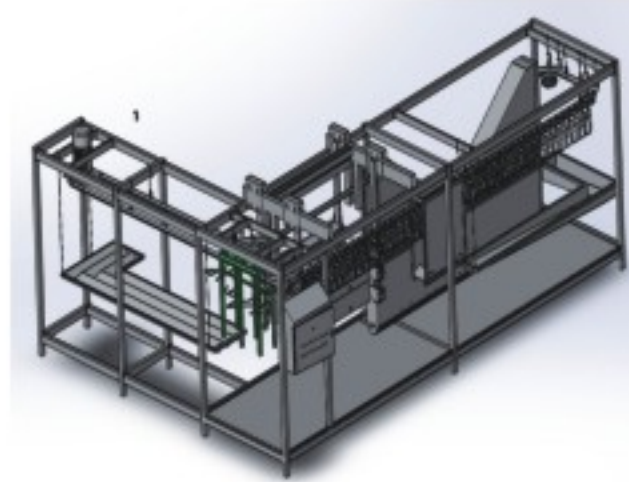

»» Code printer



»» Water dropping drum



»» Working table



»» Hand washer

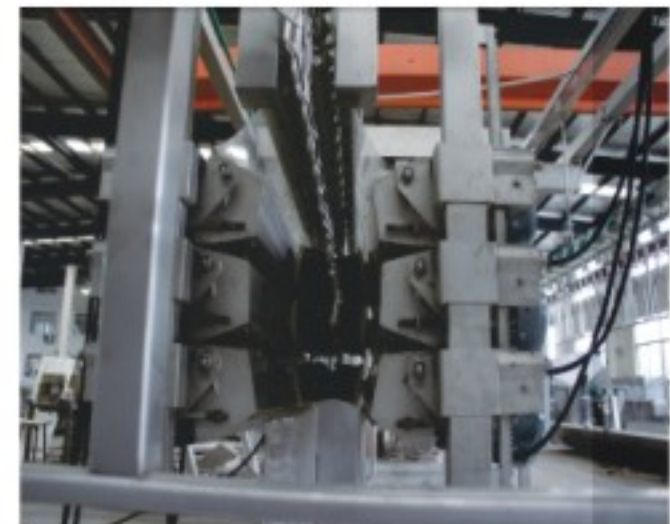

RENDERING EQUIPMENT

RENDERING PLANT FLOW

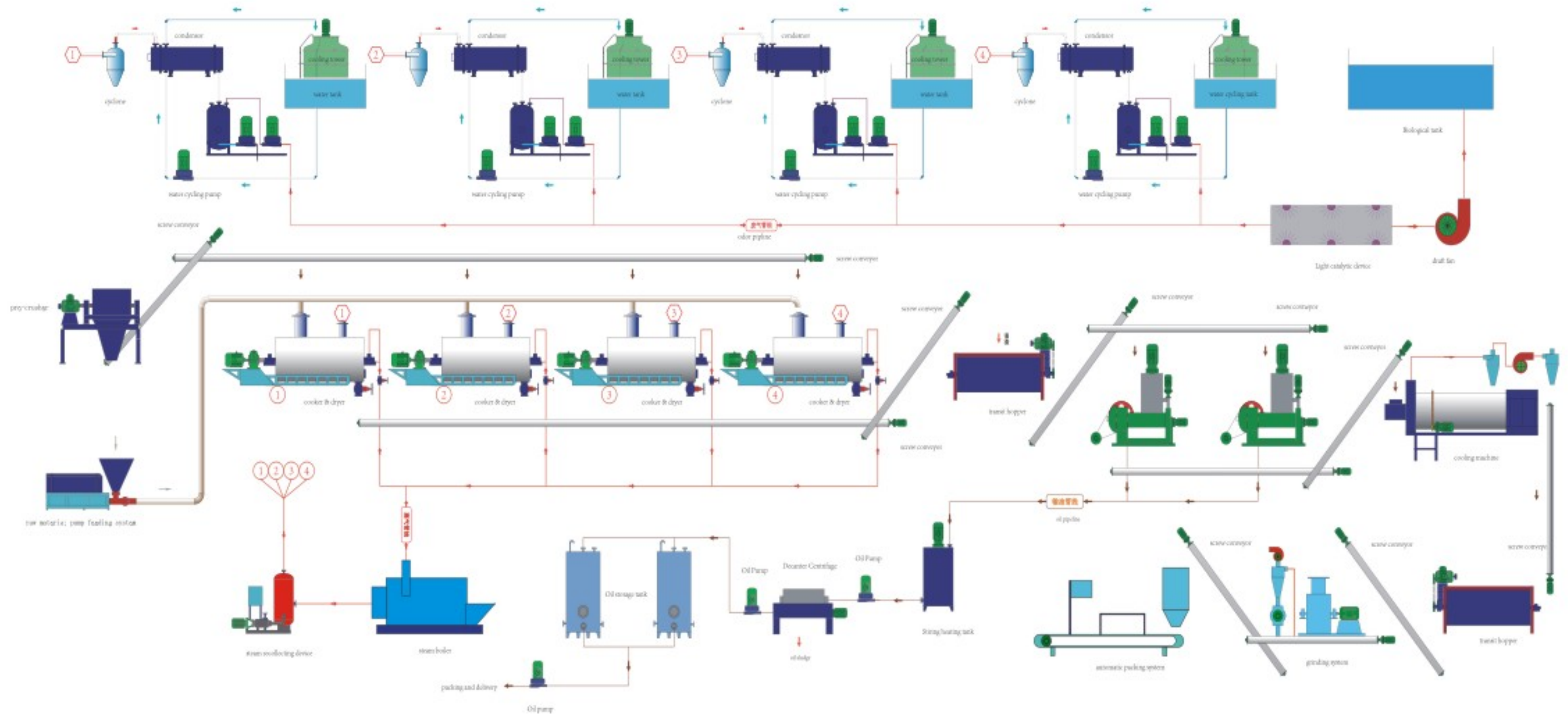

Standard Large Capacity Rendering Equipment Working Flow 60 Ton/Day

Our Successful Projects



Pre-breaker

»» product characteristics and main uses

CZYS series product has the advantages of compact structure, stable transmission, low noise and convenient installation. The advantages of reliable operation, convenient repair, energy saving etc..

CZYS series of products using the most advanced sealing combined type sealing structure, with High wear resistance and sealing, but also has the advantages of high temperature resistance, can resist all kinds of chemicals

Erosion characteristics.

CZYS series products are suitable for all kinds of poultry carcasses, animal bones, meat, sausage

film which can be processed into meat and bone meal with high temperature sterilization.

»» working principle

In the production process, due to some rendered raw material are too large size which is inconvenient loading, so it must be into pieces.

Further loading.

The working principle is that the large animal carcass is broken up into small pieces with mechanical spiral separation type rotor.

»» Model:

SQ.	Model	Power(KW)	Material
1	CZYG-50	37	Carbon steel
2	CZYG-80	45	Carbon steel

»» 产品示意图 :

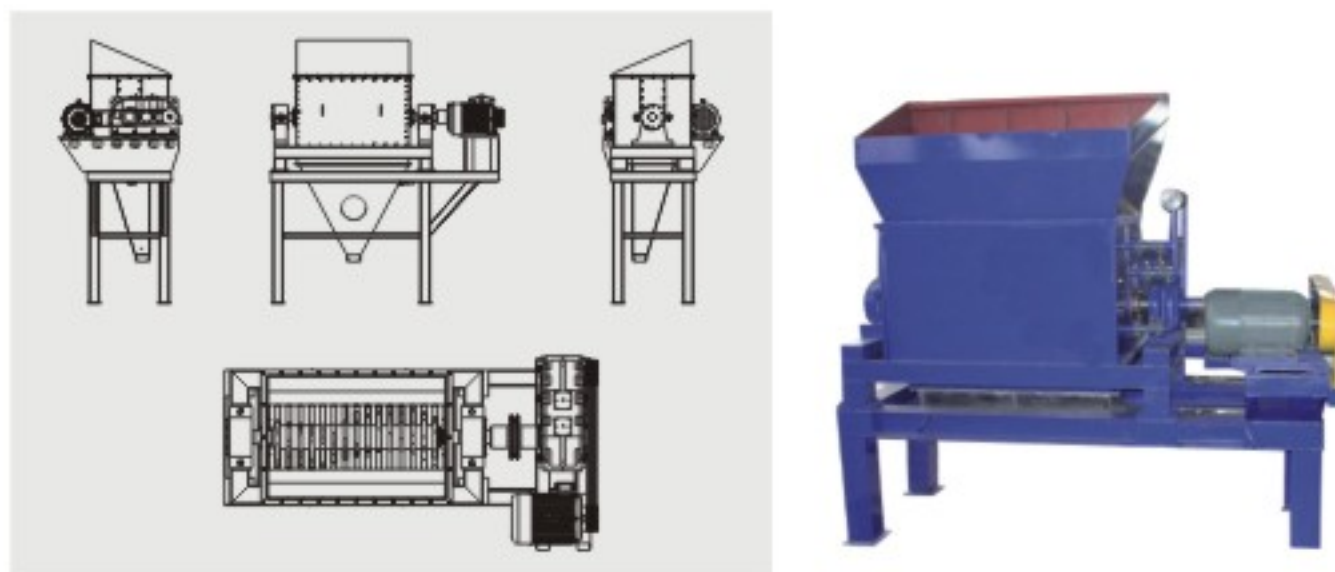

FEATHER PRESS

Feather press for separation the water from feather before feeding to cooker. The raw material of feather contains about 70% of water which just transport from slaughterhouse. After pressing by our machine, the water contains decreased to 50%. The water leaking wall and machine cover is stainless steel

»» Model and Specification

SQ.	NAME	MODEL	POWER(KW)	SHAFT DIA.(MM)
1	Feather press	CZJ350	7.5	350
2	Feather press	CZJ400	18.5	400

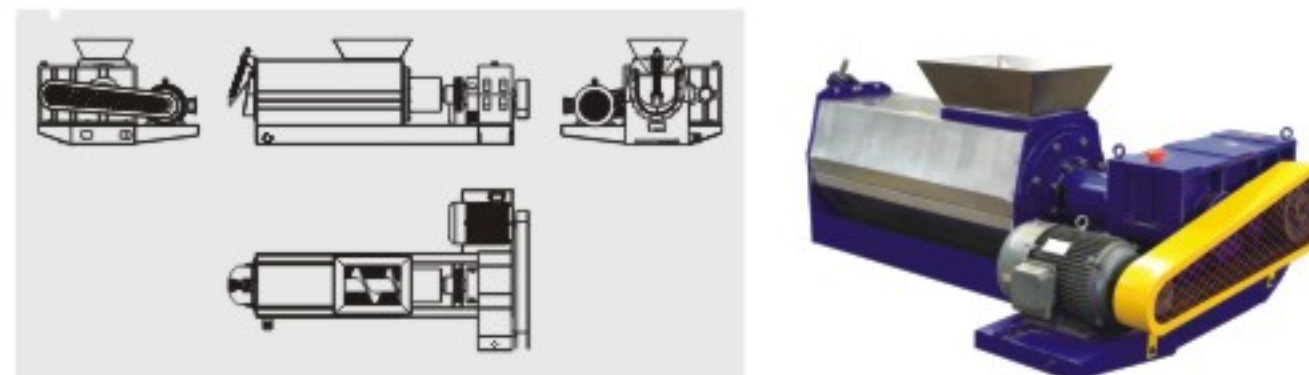

Raw Material Bin

The Bin is used to collect raw material to make automatic ,continuous work. We have series models to match with different capacity production line. After the raw material of poultry feather and viscera, dead chicken, red meat by-products, or dead animals pre-break it and then put in the raw material bin, with the screw conveyors transportation, the raw material is automatically feeding to the batch cooker.

Feathers:

Big volume: the waste can be unloaded into bin at one time from truck
Energy saving: The working speed is regulated, fully automatic work, no labors involved

Environmental protection: The bin with hydraulic power cover which stop the waste splash to outside

The standard Model Specification:

Model : CZWL--15

Volume: 15 cubic meter;

Material: Carbon Steel

Power : 11 Kw×4;

Discharge conveyor motor 5.5KW.



Pre-breaker, raw material bin & pump feeding device

This is the special design for full automatic livestock farm to render the dead animal or animal slaughterhouse waste, which realize the fully automatic working from large items pre-breaker to automatic feeding system to Cooking system. The whole process is closed working, don't have blood or residue leaking, greatly saving the labor work, especially for the big capacity rendering plant.

The raw material is transport which truck and directly unloading it into the raw material bin, which gradually feeding into re-breaker to crush it into small size, and feeding it into cooking system with pumping system.

Basic Structure:

The upper one is raw material bin which is suitable for slaughterhouse poultry or animal wastes, or farm dead livestock or poultry.

The middle part is pre-breaker with the function of reduce the large raw material size into small items which size is less than 5cm, the system is self-washing, disinfection, whole chamber is full closed, which stop workers touch livestock or poultry and stop the bacteria spreading.

»» Main technical parameters of CZWL-15 raw material Bin

SQ.	Item	Specification
1	Spindle feeding cabin	Diameter 4 350mm Lead350mm
2	Connecting screw conveyor	Diameter 4 500mm Lead400mm
3	Feeding bin couplings	1.5 inch 22 teeth
4	Discharge auger double strand round	1.5 inch 18 teeth
5	Belt length	B Type -2642mm
6	Motor	11KW-4P
7	Hydraulic coupling device	YOXP-320
8	Speed reducing machine	GRSZ137AD-59.51-M1
9	Pin gear box	DWD5-59-5.5KW
10	Air cylinder	Model:SC125X1200
11	Dimensions	Length 7350X width 3400X height 4520

»» Main technical parameters of Pre-breaker

Model	Power (KW)	Speed (r/min)	Material
CZWF-450	22+5.5	4200	Carbon steel
CZCF-B50	18.5+3	2800	Carbon steel
CZCF-B60	30+3	2800	Carbon steel

Pumping system Parameter:

Model : CZSB-5 Power : 18.5KW Material: Carbon steel

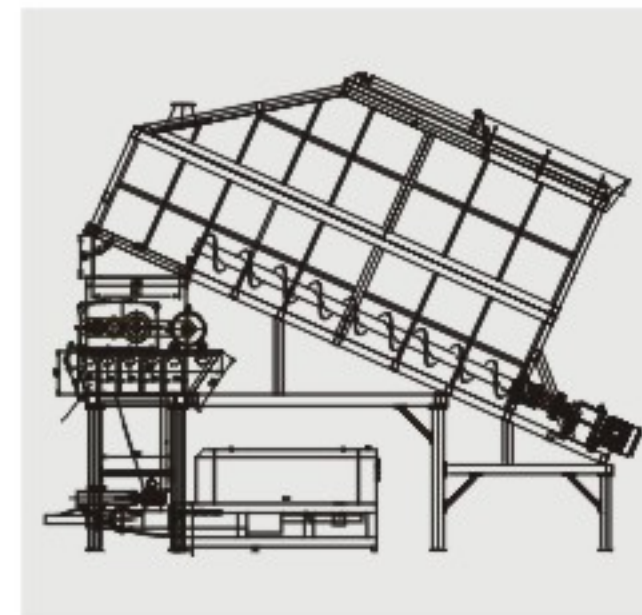

Batch cooker

»» Characteristic

1. This equipment have advantages of compact system, Smooth transmission, low noise, Easy installation, Easy maintenance, Reliable operation, Energy savings, etc.
2. It is using the most advanced modular sealing structure, with a high wear resistance and sealing, meanwhile, has the characteristic of High temperature, can resist the erosion of various types of chemicals.
3. The transmission of batch cooker is chain drive system, which has the characteristic of Smooth transmission , vibration , wear , etc.
4. The machine uses inflatable rotor shaft to accelerate the heat transfer between the body and the material which greatly improves the work efficiency.

»» Principle of Operation

After raw material hydrolysis in cooker for 30 minutes, Stamp the seal to make temperature reach 130 degrees in order to kill the E., and break the keratin molecules ,keep the working pressure for 15 minutes when it reaches 0.3mpa, discharge vapor in the tank. Heating was continued for 20 minutes, then the discharge spout into the dryer for drying. Cooled and crushed into powder. so it Becomes , protein content > 80 % , moisture <10% , tawny hydrolyzed feather meal.

»» Technical Parameters

Model	Size of Tank		Consumption (kg/h)	capacity (t/batch)	Motor power (KW)	Gear motor
	Inner Dia. (mm)	Length (mm)				
CZSJ1300-4	1300	4000	300	1.5	22	ZSY280
CZSJ1400-5	1400	4000	300	1.75	30	ZSY280
CZSJ1400-6	1400	4500	350	2	37	ZSY 280
CZSJ1500-7	1500	5000	500	2.5	45	JZQ750, JZQ850
CZSJ1600-8	1600	5000	550	2.75	55	JZQ850, PV
CZSJ1700-10	1700	5000	600	3	55	JZQ850, PV

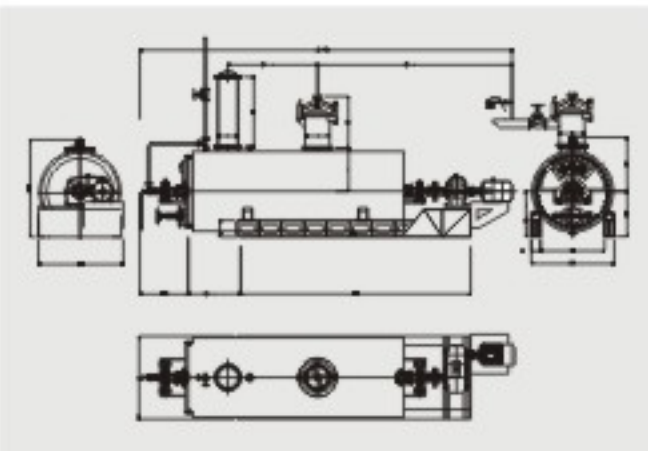

Digester (Combined with cooking and Drying process)

Digester realize the easy handling of odor process result, which is the upgrade of Batch cooker and combined cooking and drying in one equipment. Clients are easy to operate the odor system, and processing is more stable. The working process is same as batch cooker for cooking stage, after cooking, the meal dried in same machine, no need discharge it and drying in dryer. The cooking time is about 1.5hours, and the drying time is about 2.5 hours. Water contains is around 10% after drying.

»» Characteristic

1. This equipment have advantages of compact system, Smooth transmission, low noise, Easy installation, Easy maintenance, Reliable operation, Energy savings, etc.
2. This equipment is using the most advanced modular sealing structure, with a high wear resistance and sealing, meanwhile, has the characteristic of High temperature, can resist the erosion of various types of chemicals.
3. The machine uses a chain drive coupling power transmission structure, which has the characteristic of Smooth transmission , vibration , wear , etc.
4. The machine uses inflatable rotor shaft to accelerate the heat transfer between the body and the material greatly improves the work efficiency.

»» Model:

This specification refers to the CZHZ series products are mainly including the following specifications of products:

CZHZ-1300-4 CZHZ-1400-5 CZHZ-1400-6
CZHZ-1500-7 CZHZ-1600-8 CZHZ-1700-10



Model	Tank size		Inside diameter (mm)	Yield (t/batch)	Motor power (KW)	Reducer
	Inside diameter (mm)	Length (mm)				
CZHZ1300-4	1300	4000	300	1.5	22	ZSY280
CZHZ1400-5	1400	4000	300	1.75	30	ZSY280
CZHZ1400-6	1400	4500	350	2	37	ZSY 280
CZHZ1500-7	1500	5000	500	2.5	45	JZQ750, JZQ850
CZHZ1600-8	1600	5000	550	2.75	55	JZQ850, PV
CZHZ1700-10	1700	5000	600	3	55	JZQ850, PV

Disc. Dryer

The disc. Dryer is combined with drum-type rotor and casing.

It is an high efficiency humidity drying machine.

The raw material is heated by disc plate when it feeding in dryer.

Under the action of block powder board, copying powder board and pushing board forward constantly,

it drying gradually during this process.

The water vapor is discharged from top discharging pipe

which can be used as heating source of the equipment, the finished product is transport by screw conveyor.

This machine is especially suitable for drying material which is high moisture and high consistency. Disc. Dryer is a new energy efficient dryer.

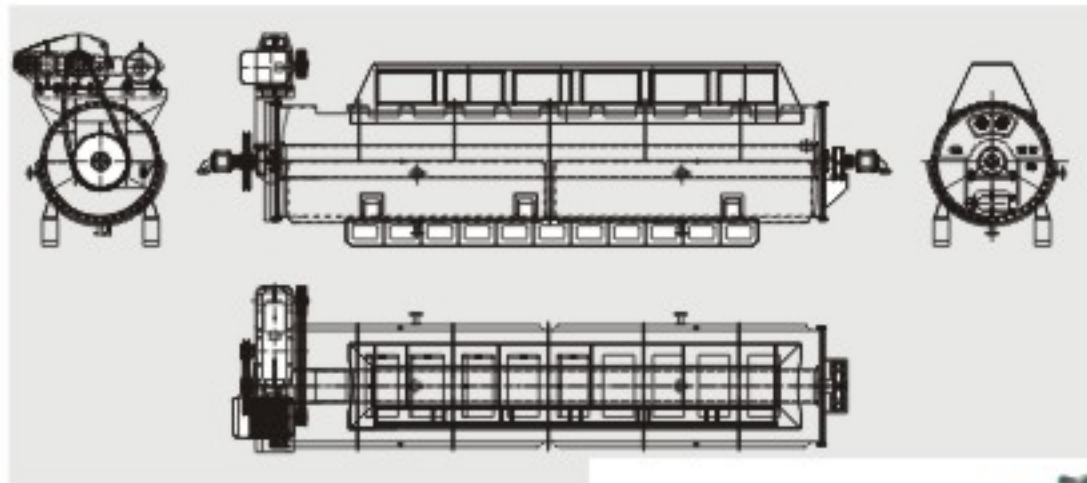

Model	Tank Dimension		Cooling area m ²	Evaporation of water kg/h	Motor power kw	Reduce JZQr
	Rotator dia. mm	Length mm				
CZP1200-6	1200	6000	80	350-450	18.5	500
CZP1300-7	1300	7000	100	550-650	22	650
CZP1400-7	1400	7000	130	650-750	30	650

Tube Dryer

Tube dryer working result is same as Disc. Dryer, which all used to drying the meal. The tube dryer working with heat conduction and heat radiation way, the material is moving ahead with negative pressure closed chamber, the material move from inlet to the outlet and rapid drying.

Suitable for feed, chemical, fertilizer ...etc which with different proportion of small loose material and moisture sticky granular, fibrous, and powdery material.

» Feature:

It is compact structure, smooth transmission, low noise, easy installation and maintenance, reliable in operation, energy saving and other advantages.

The rotator is seamless steel tube, which with big heating release area and increase the connection with material, drying result is good and fast.

The structure of equipment is chain driving transmission, which smooth transmission, vibration reducing, and wearable.

The working model is continuous working

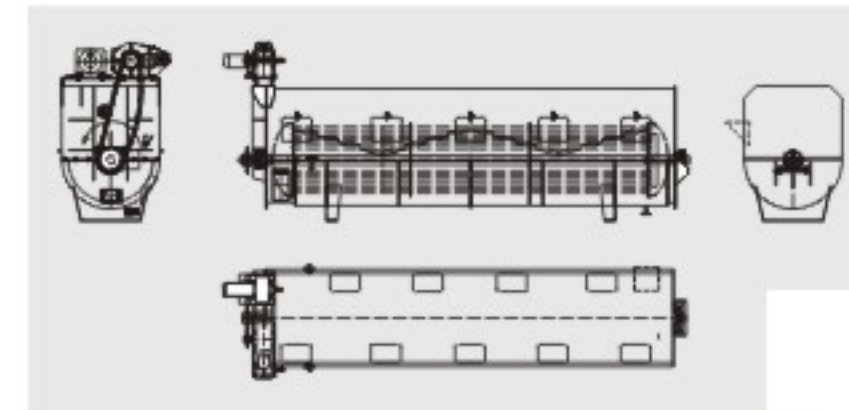

» Model:

SPECIFICATION	Main power (kw)	Heat Exchange (m ³)	TRAP (kg/h)	EVAPORATOR (kg/h)	ROTATING SPEED (r/min)
LYS120	11	120	3500	550-650	5-8
LYS140	11	140	4000	650-750	5-8
LYS160	15	160	4500	750-850	5-8
LYS180	18.5	180	5000	850-950	5-8

Fat Press

Fat press is composed of the following main parts: material receiver, feeding system, pressing camber, squeezing screw shaft (including cake regulator) and transmission device.

1, Material receiver

This equipment is installed on the frame of the rack, which is composed of an auger, driven gear box motor.

2, Feeding system

Feeding system is composed spiral leaf pressing which at lower end shaft and a feed dropping hopper from where the working status can be monitored and shaft working.

3, Pressing chamber and squeezing screw shaft

Pressing chamber and squeezing screw shaft is the main component of this equipment, the cooked meal dropped into pressing chamber and squeezing shaft, due to the rotating of shaft which reduced the squeezing chamber space, the meal pressed and oil separated from it, the oil flow down from the gap of pressing strip

»» Main technical parameters

SQ.	Item	400-500KG/H	
		CZZ-400	CZZ-800
1	Capacity	7-10Ton/24Hours	16-20Ton/24hours
2	Dimension	2900*1850*3240mm	4625.5*1920*3993mm
3	RMP/min	10-12r	20-22r
4	Current (A)	40-60	40-60
5	Power (kw)	18.5+3+1.5	72
6	Pressed cake thickness (mm)	6-12	6-12
7	Oil remain in cake (1st time) %	8-10	8-10
8	Weight(KG)	5000	9160
Working condition			
9	Temperature °C	20	20
10	Design temperature °C	30	30
11	Relative humidity %	65	65
12	Atmospheric pressure (Mbar)	1013	1013
13	Ambient lighting	> 300LUX	> 300LUX
14	Main power supply	> 18.5kw	> 72kw
15	Main current	< 40A	< 40A
16	Main power supply	18.5kw back start	72 kw back start



Meal Cooling & Filter

»» Product characteristics and main uses

CZZS series rotary cooling tank, is a new type of cooling device of a particularly strong adaptability.

The CZZS series device controllable high performance, stable product quality, convenient operation, more suitable for the high temperature material cooling of feed, chemical industry, is a new generation of cooling industry energy saving and environmental protection equipment.

Cooling and screening of CZZS series of products applicable to all kinds of feed.

The CZZS series products are mainly including the following specifications of products:

CZZS-1300-1 CZZS-1300-2 CZZS-1500-3

»» Working principle

The production of feed, which discharged from the dryer must filtered and chilled by this cooling machine to achieve the purpose of cooling and dewatering. In the existing equipment configuration, there are mainly two kinds of granular feed cooling device, one is vertical type cooling machine, the other is the counter flow type cooling machine. Its principle is with feed high temperature which discharged from drying machine which is generally 70 – 80°C, The water contents of feed can reduce about 3% after chilled by fans, and cooling and drying the meal.

3.working principle

»» The main technical parameters of CZZS series

model	Tank size (mm)		Design output kg/h	Motor power (kw)	Texture of material (Stainless steel / steel)
	Diameter	Length			
CZZS1300-1	1300	4000	750-1000	3	optional
CZZS1300-2	1300	6000	1000-1500	4	optional
CZZS1500-3	1500	8000	1500-2000	5.5	optional

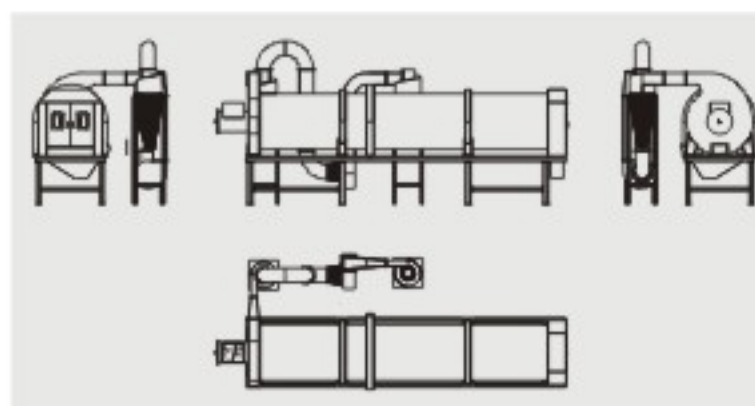

Grinder

»» The Main use

This grinder is mainly used to crush the granular or strip feed, such as corn, rice, wheat, Gu Li, Bakelite, plastics, fish meal, feather powder, hay, straw, dry beans and so on, also can be used for other purposes, such as crushed charcoal, bone carbon. After crushing fineness can borrow the choice of proper aperture sieve adjusted. Artificial feeding, screw feeding, with dust collector, can be equipped with 0.5T or 1T mixer into supporting units (with 2.5 meters elevator).

Hammer type crusher adopts a direct drive; optional high intensity magnetic separation device; optional automatic uniform feeding mechanism, the feeding quantity can achieve automatic control; the main part of the rotor, the high-precision dynamic balance test, can rotate in positive and negative direction; special hammer after heat treatment processing, good quality, long service life, the crushing rate high; with self-locking device operation door, convenient and flexible, safe and reliable. Advanced and reasonable, the machine overall design, compact structure, beautiful appearance, yield better than similar products, low power consumption, convenient operation and repair. It is widely used in food, feed, wine, food, chemical plant raw material pulverization, simple installation.

»» Technical parameters

Auxiliary power: 18.5kw

Spindle speed: 2900/min

The crushing chamber width: 270mm

Hammer number: 16 pieces

The hammer sheet size: 50mmx160mm

Cutting face: 270mm

Sieve quantity: 1

Sieve size: 270mmx860mm

Size: 1200x520x1500

Production capacity: 1-2T / h

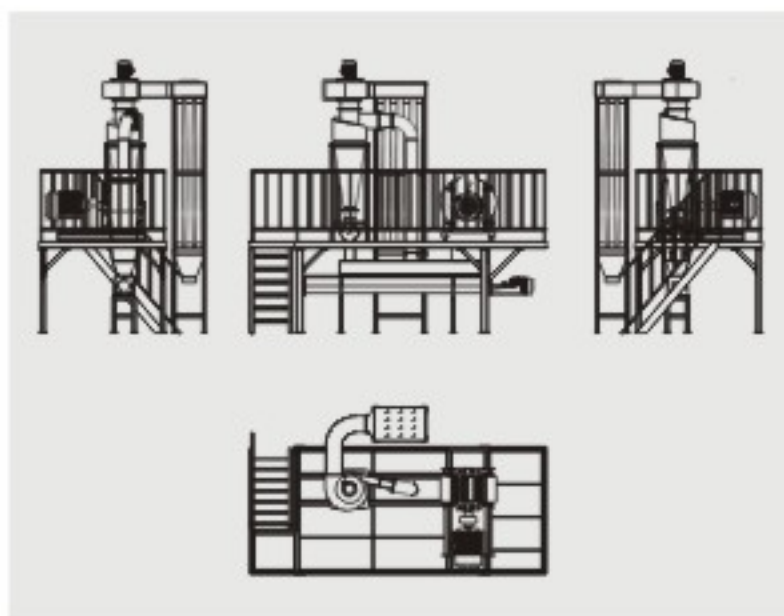

Vacuum Station

»» Characteristics and main uses

CZBZ series vacuum pump is used for extraction of odor air or pressure, and other non corrosive, insoluble in water, containing no solid particles, so as to form vacuum or pressure condition in the closed tank, to meet the requirements of the specific process of odor system.

CZBZ series vacuum pump station is widely used in machinery, petroleum, chemical, pharmaceutical, food, ceramics, sugar refining, printing and dyeing, metallurgy, environmental protection and electronic industries.

CZBZ series vacuum pump station has the advantages of compact structure, stable transmission, low noise, convenient maintenance, simple installation and reliable operation, energy saving etc..

CZBZ series of products using the most advanced sealing combined type sealing structure, has high wear resistance and sealing, but also has the advantages of high temperature resistance, can resist all kinds of chemical erosion characteristics.

»» Model:

There are two models of CZBZ-0.4-1 and CZBZ-0.4-2

SQ.	Model	CZBZ-0.4-1
1	Vacuum tank volume(Liter)	400
2	Waste water tank (Liter)	75
3	Vacuum pump power(KW)	4
4	Vacuum pump Qty.(SET)	1
5	Waste water suction pump power(KW)	2.2
6	Waste water suction pump Qty.(SET)	1
7	Qty. of control panel (SET)	1
8	Control Panel	CHNT

Working principle

CZBZ series vacuum pump station working principle is that the vacuum pump extract the compressed air from Cooker or digester, and water pump get condensate water from condenser, to achieve the drying of materials and process odor and waste water. The whole process is central automatic control.

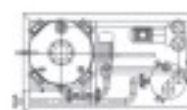
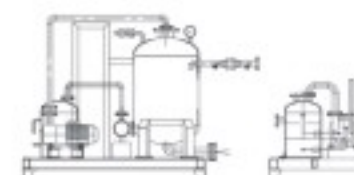

Cyclone

Cyclone is used to collect large particles when the Batch cooker Digester start to relief pressure, also the pressure goes away with odor. Cyclone is pressure resistance.

The working process

The airflow inside of cyclone is rotating movement, and steam of dust particles is separated from the odor due to centrifugal force. It is centrifugal dust removal technology which worked with centrifugal force to remove the dust. It mainly composed by cylinder, cone, odor intake pipeline and dust exhaust pipeline.

The working theory

When the dust goes with odor from dryer pass through cyclone, the air steam is approaching from the shape linear into rotary movement, and downward along the wall of cylinder with the spring shape, and toward the cone, usually call it external rotation airflow. During the airflow rotating, it generate centrifugal force, and the relative higher density particles is forced to the wall which lose the radial inertia fore and momentum, and along the gravity down into the dust discharging pipeline.

The features

1. There are no moving parts inside the cyclone, Easy maintenance.
2. It is convenient in manufacturing and management.
3. Handling the same amount of odor, the size is small, simple in structure and lower in cost
4. Easy installing
5. The more than one set of cyclone can be used when process large amount of odor, efficiency and resistance is not affected.
6. The withstand temperature reach to 400 °C
7. Used to catch the particles size which is from 5-15um

» Model:

SQ.	Name	Model	Diameter (mm)	Sheet thickness (mm)	Height (mm)	Material
1	Cooker & Digester cyclone	CZ900-A	900	3	2500	SS 304
2	Dryer Cyclone	CZJ-900	900	1.5	2500	SS 304

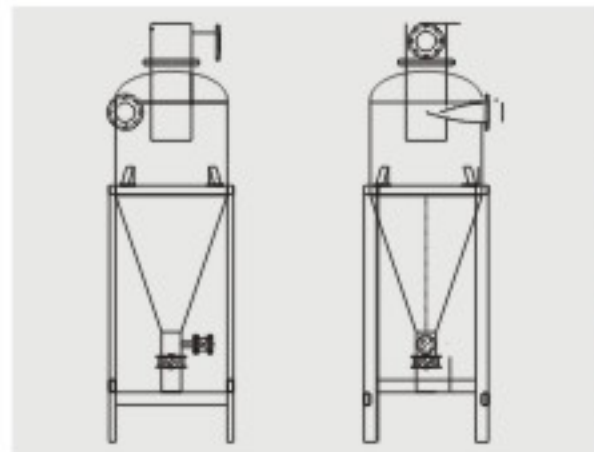

Condenser

» Characteristics and main uses

CZSL series of condenser is a relatively simple structure, convenient repair, heat exchanger with high thermal performance. According to the material is divided into three kinds, which are carbon steel condenser, stainless steel shell condenser, Carbon and stainless steel combined condenser. According to the form is divided into three kinds which are fixed tube plate model, floating head model and U shape tube model, which are heat exchanger device. According to the structure is divided into single tube pass, double tube passes and multi tube passes. The heat transfer area is from 0.5 to 500m², the actually size needed is according to the whole rendering system capacity.

CZSL condenser is widely used in animal feed factory, chemical plant, power plant, and refrigeration machinery.

Working principle

CZSL series of condenser water is used as cooling medium, depending on the water temperature rise to take away heat of condensation. Cooling water is circulated working, it have to work with water cooling tower or a water cooling tank. The water cooled condenser is divided into shell and tube condenser and the sleeve pipe type condenser according to structure, common is the shell and tube condenser.

Characteristics of shell and tube condenser

1. Cooling water is straight pass through tube and the flow velocity is large, so don't request high water quality, which normal water can be used as cooling water.
2. It is easy to remove scale on pipe and no need power off refrigeration system.
3. The shell and tube condenser is compact in structure, small size, and less installation area needs.
4. High heat exchanging area.
5. There is big difference of chilled water come in and out, less water consumption.
6. Easy operation

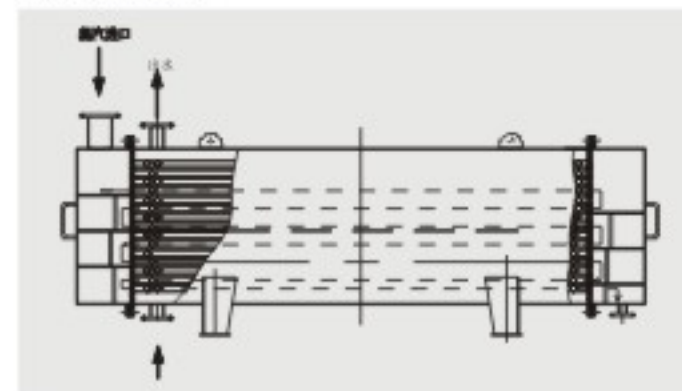

» Model and main technical parameters

Model	Nominal diameter	Tube pass	Pipe Qty.	Area of heat exchange nominal value / calculated value					Tube channel cross-sectional area of the tube side flow passage is 0.5m/sec flow m/hr		Nominal pressure
				The length of tube (m)					φ25×2.5		
				1500	2000	3000	4000	6000	φ25×2		
CZSL400	400	1	119	14/13.47	18/18.41	28/27.76	37/37.10	55/55.8	0.0374/0.0412	67.32/74.16	1.6
		2	110	13/12.70	17/17.02	26/25.66	34/34.20	50/51.58	0.0173/0.0190	31.14/34.20	2.5
CZSL500	500	1	185			45/4.15	55/57.68	85/86.74	0.0581/0.0641	104.58/115.38	
		2	180			40/41.99	55/57.68	85/86.74	0.0283/0.0312	50.94/56.16	
CZSL600	600	1	269			60/62.7	85/83.88	125/126.13	0.0845/0.0932	152.10/167.76	
		2	266			60/32.05	80/82.94	125/14.72	0.0418/0.0461	75.24/83.98	
CZSL700	700	1	379			90/88.41	120/118.17	175/177.71	0.0091/0.1313	214.38/236.34	
		2	358			85/83.51	110/111.62	165/167.85	0.0562/0.0620	101.16/111.60	
CZSL800	800	1	511			120/119.20	160/159.16	240/239.60	0.1605/0.1770	288.90/318.60	
		2	488			115/113.83	150/152.16	230/228.81	0.0767/0.0845	138.06/152.10	
CZSL400	900	1	649			150/151.39	200/202.36	305/304.3	0.2039/0.2248	367.02/404.46	
		2	630			145/146.96	195/196.44	295/295.40	0.0990/0.1091	178.20/196.38	
CZSL400	1000	1	805			185/187.78	250/251.00	375/377.45	0.2529/0.2788	455.22/501.74	
		2	792			185/184.75	245/246.95	370/371.36	0.1244/0.1374	223.92/246.96	

Chemical Washer

» Characteristics and main uses

The purification efficiency and reliability

In the study of the development process, in order to verify the performance of products, our company specially invited the relevant environmental protection department of the CZXD series of the products in the exhaust gas purification tower was simulated production test, made a large number of data, through sorting, hydrogen chloride (HCl) gas purification efficiency up to 96.3% on average, sulfuric acid mist (H2SO4) average the purification efficiency of 93.2%, alkali fog (NaOH) the average absorption efficiency of gas 95%.

Reasonable structure design

CZXD series of exhaust gas purification tower for wet absorption purification equipment, its function design for packing, spray packet classification type. When the waste gas treatment is acidic, generally adopt sodium hydroxide (NaOH) as the absorption and neutralization liquid. When the waste gas treatment is basic, the general use of neutral or acidic water washing water. Its working principle is: the pressure equalizing chamber exhaust gas by the fan pressure into the purification tower composition to inner and outer jacket, so the exhaust gas through the air uniform grid into a uniform level filling function section, a spray, the gas-liquid two-phase get a full contact, through the exhaust level after treatment with a flaring segment deceleration enter the two stage filling spray function section, and then make the exhaust gas can be more fully

Gas-liquid contact reaction, and then by the removal of liquid for liquid removing fog, exhaust outlet duct into the atmosphere by the. After treatment of the exhaust gas emissions can reach the national emission standard.

Varieties, specifications

This specification refers to the CZHZ series products are mainly including the following specifications of products:

CZXD-1400-5 CZXD-1200-5 CZXD-1800-6

Working principle

The exhaust gas from the fan is pressed into the pressure chamber purification tower evenly, and then enters into the inner barrel processor. Air through the two layer of filler and then through two spray treatment, the gas-liquid two-phase full contact the occurrence and the absorption reaction,

Then enter the liquid removing device for de liquid treatment after the air from the exhaust pipe into the atmosphere.

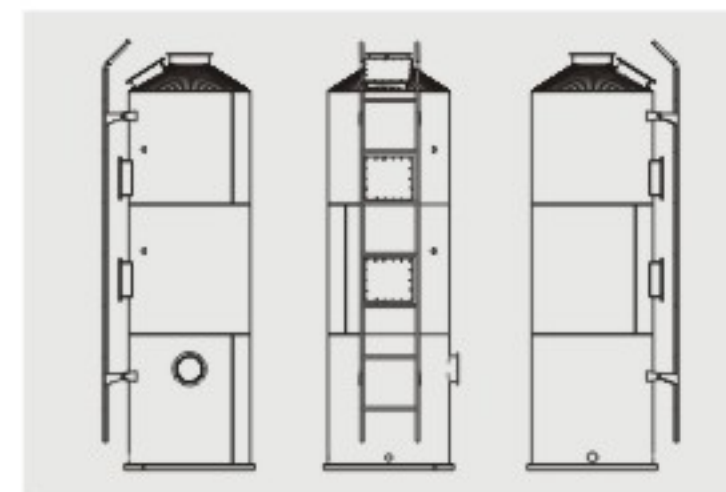

»» The main technical parameters

specification		3	5	7.5	10	15	20
Air handlingm ³ /h		3000	5000	7500	10000	15000	20000
Auxiliary fan	model	GBF-4-72-12					
	specification	4.5A	4.5A	5A	5A	8C	8C
	Power (KW)	7.5	7.5	15	15	22	22
	The residual pressure (Pa)	588	392	1019	813	490	392
Pump	model	FS					
	specification	40FS-30	50FS-30	50FS-30	65FS-35	65FS-35	65FS-35
	Power(KW)	3	4	4	5.5	5.5	5.5
Absorption and neutralization liquid		2-6%NaOH					
The concentration of exhaust gas entrance	Nox	About 3000mg/m ³					
	H ₂ SO ₄	<600mg/m ³					
	HCL	<600mg/m ³					
Purifying power	NOx	90%					
	H ₂ SO ₄	94%					
	HCL	>94%					
The shape size	dimension	1400	1500	1700	1800	2000	2100
	dimension	4600	4500	4600	4000	4800	4800

Screw conveyor

CZLO/CZLU screw conveyor is manufactured according to ISO9001 2000 standard, design and manufacture are following standards. The screw diameter of CZLO/CZLU screw conveyor is from 100 mm to 1250 mm, which are totally 12 models. There are two type according to transmission system which are single driver and dual driver. The screw conveyor length is reach to 40meter for single driver, which dual driver model can reach up to 80 meters which have connection of main shaft in middle. The main shaft is formed by special structure design, less resistance, sealing strong, good wear resistance, long service life. The location of the inlet and outlet arrangement is flexible, can be equipped with electric discharge port for automatic control. CZLO/CZLU screw conveyor has the characteristics of novel structure, advanced technical index, strong adaptability, convenient repair operation:

It is widely used in building materials, metallurgy, chemical, electric power, coal, machinery, light industry, food and food industry, suitable for conveying powder, granular, small bulk materials, such as cement, coal, grain, fertilizer, slag, sand, coke and other: for conveying perishable, viscous, easy caking materials. The working environment temperature of LS model screw conveyor is usually 20 to 40 DEG C, the material temperature is general 20 to 80 DEG C. LS screw conveyor is suitable for installed with small inclination angle and level working. It is better not more than 15 degrees. If there are special requirements may consult with the manufacturer, special design.

»» Working principle

- 1, Large carrying capacity, safe and reliable.
- 2, Strong adaptability, convenient installation and repair, long service life.
- 3, Small body, high speed, to ensure rapid and uniform transportation
- 4, Good sealing, shell is made of seamless steel pipe, the end flange is connected to each other as a whole, rigid



»» Model:

Model	Power (KW)	Pitch	Speed(r/min)	Shaft Dia. (mm)	Drum Dia. (mm)
CZLO-165	1.5	135	62	60	168
CZLO-219	3/4	170	62	89	219
CZLO-350	5.5	280	62	114	350
CZLU-250	4	210	62	89	250
CZLU-300	4/5.5	280	62	114	300
CZLU-350	5.5	310	62	114	350
CZLU-400	5.5/7.5	320	62	140/114	400
CZLU-500	7.5/11	350	62	168	500

Transit Hopper

Meal Transit bin the transit meal hopper which used after the meal cooking in batch cooker and before feeding to the next process of drying or pressing which gives the enough time for continuously working for meal drying or fat pressing. The system is constructed by the screw shaft which mixing the meal and drives meal from entry to exist.

The features are simple in structure, stable is operation, low energy consumption, durable for lifetime.

Tank diameter is 1200mm, the thickness of tank body is 10mm. The main shaft diameter is 219 mm, shaft material thickness is 14mm, The tank length according to the different line capacity request, from 5meters ling to 8 meters or some other dimensions. The material is carbon steel with the stainless steel cover. The system with driving system of gear box motors. The power is from 7.5kw to 15kw.

Model:

SQ.	Model	Width (mm)	Sheet δ (mm)	Shaft Φ (mm)	Shaft δ (mm)	Length (mm)	Material	Power (kw)
1	CZHC-3	1460	8	180	12	3000	Carbon sl.	7.5
2	CZHC-4	1460	8	219	14	4000	Carbon sl.	11
3	CZHC-5	1460	8	219	14	5000	Carbon sl.	15
4	CZHC-6	1460	8	219	14	6000	Carbon sl.	15
5	CZHC-7	1460	10	245	14	7000	Carbon sl.	15

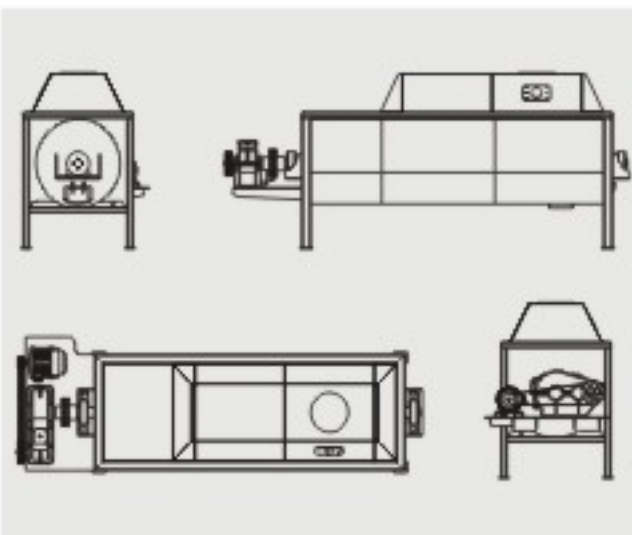

COMPACT rendering equipment

Characteristics and main uses

1. Product features and main uses

CZW serial products is compact and small installation area required; stable in transmission, low noise; Easy operation, simple maintenance, reliable operation and save energy.

CZW serial products use the advanced technical of combined sealing structure, which with the high wear resistance and sealing, at the same time ,this serial production can bear the high temperature, and resist the corrosive properties of various types of chemicals.

CZW serial products' driving unit is FAF which is a speed variable device, which reduce the friction caused by the intermediate connecting member; FAF driving unit working stable, save energy.

CZW serial products is suitable for different kinds of poultry feather, animal hide and hair, offal, meat remains, intestinal and others, which all can be turned into autoclaved feather meal, meat or bone meal, etc.

When pressure reach to 0.2-0.3 Mpa and keep it for about 15minutes, during this time, the temperature of material is about 130°C, which to kill E. coli and other bacteria; After that relief the steam in cooker which go to odor processing device; According to the features of different kind of raw material keeping heating for about 4-5 hours, the drying is complete during this time, and discharge the meal and storage it as the fertilizer or feather meal.

Note: If the processed raw material with fat, the oil pressing device can be added to remove the fat, separating device which used to separate the oil and fat; the final production is meat or meat bone meal, and oil which is easy storage and high profit in recycling.

3.CZW Serial main parameter



Model:

Model	DIMENSION			Capacity (T/batch)	Power (KW)
	Length (mm)	Width (mm)	Height (mm)		
CZW-1000	9000	2300	5000	1	23

MODERN BROILER HOUSE



Chicken Raising Equipment

>>> The Nipple drinking system

The outside of nipple use high quality engineering plastic, the internal stem is stainless steel, whole parts is corrosion resistance whose lifetime up to ten years.

Internal with double sealing, which is reliable in sealing, avoid the water linkage may cause the affection on house humidity.

Stem can be 360 degrees movement, which is suitable for different stage of broiler.



Nipple

The outside cover is made of raw material which is imported from Korea.

Features: high strength, high wear resistance.

All stainless steel components are manufactured with raw materials which imported from Germany.

Features: high abrasion resistance, abrasion resistance, high quality finish.

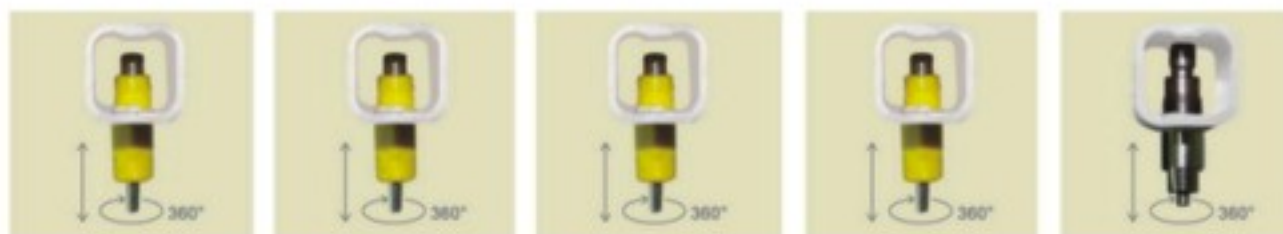

>>> Model:

HB120	HB80	MY120	MY80	SS
80-120ml/min	50-80ml/min	80-120ml/min	50-80ml/min	50-80ml/min
Broiler duck	Breeder, layer	Broiler, DuckBreeder,	layer, Duck	Breeder, layer, Rabbit
8-12piece/ nipple	8-12piece/ nipple	8-12piece/ nipple	8-12piece/ nipple	8-12piece/ nipple

Our nipple drinker is name as the China national poultry nipple drinker standard setter by National ministry of Agriculture

Nipple drinker is sensitive and reliable 360 degree water outlet, which fully meet the needs of the drinking water in all chicken growing stages.

During the working, the friction of steel makes more sealed which guarantee the long life period of nipples which reach to 15 years.



Pipeline

The pipeline is manufactured with high quality PVC pure raw material, pipe diameter is 22*22mm, wall thickness is 2.2mm.

The raw material with additive powder In addition to avoid imported powder. (features: due to the sunlight the moss and other impurities are grows inside pipe, Prevent the leakage of the nipple)

With anti ageing agent, which Maximum extended service life.

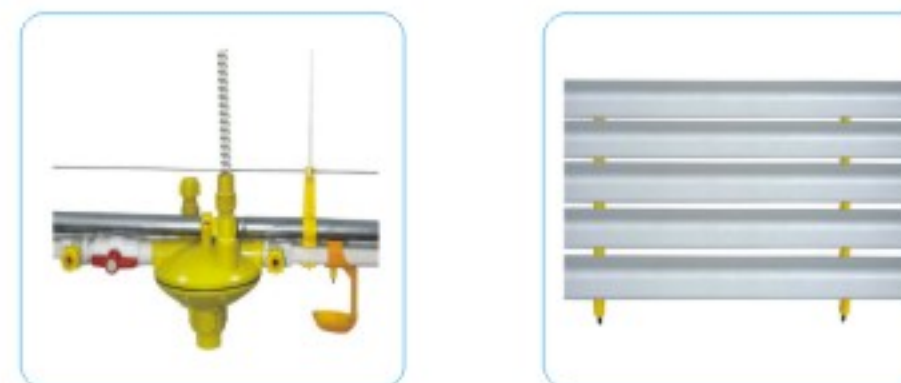

Pressure regulator

With an automatic flushing device, the impurities which are in the pipeline can be rapidly flushing away.

High pressure resistance, the maximum pressure loading is 40bar.

The longest length of drinking line is 150 meters.

Display tube is made of high transparency, high toughness and impact resistance plastic, which is durable, it is more clear to observe the water level, and easy disassemble and clean

The front part of drinking line

Filtrating the impurities in water.

Accurate measurement of water consumption

Medicator: water supply is closed, and add the vaccines or medicine according to different proportions of vaccines.



Medicator

We use the world's best brands - France Dosatron Mediator

Mediator is taken water as power, no electric consumption, economical and reliable. Which is easy operate, and accurately control the amount and proportion of the medicine.

Technical Parameters

1. Working flow: 10L / h-2.5m³ / h
2. Working pressure: 0.3bar-6bar
3. Medicine injection speed: 0.02L / h-50L / h
4. The maximum operating temperature: 40 °C
5. Adjust ratio: 0.2% -2% (1: 500-1: 50)



»» Feeding system

Feed Silo

Main feeding line system consists of automatic driving device, a silo, a conveying pipe, an auger and a feed sensor. The main feeding line system is mainly used to convey the feed in the silo into the hopper of the feeding line and automatically control the conveying opening/closing of the motor by the material level sensor to achieve the aim of automatic feeding.

Performance parameters of main feeding line system

- 1, High-quality special driving reduction motor
Power: 0.75kw, voltage: 380V, frequency: 50HZ, three-phase AC current
- 2, Feeding system

Diameter of conveying pipe: 675*3.6mm, material: PVC

Helical spring auger from South Africa, Feeding ability: 1,400kg/h, maximum conveying length: 60m

Radius of bending pipe: R1500 (inclination angle: 30 degrees)

3, Material level sensor from Israel: time delay range 0 to 2 hours



»» Feature:

Zinc coating: 180g-275g / m²

Thickness: 1,1.2,1.5mm

Cone bottom reinforcing ribs

Observe port: Observation of feed Level

Feed discharging outlet: Single outlet, double outlet, the three outlet, four outlet

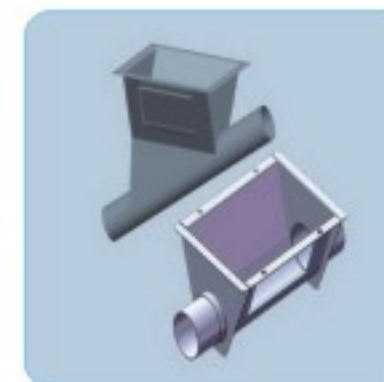

»» Model:

SQ.	Model	Loading Capacity(Ton)	Volume (m3)	Height (m)
1		Diameter (Ø) 1.8m		
2	18-0060-1	2.5	4.2	3.6
3	18-0060-2	4.0	6.5	4.5
4	18-0060-3	5.0	8.8	5.4
5		Diameter (Ø) 2.7m		
6	27-0060-1	7.0	11.8	4.8
7	27-0060-2	10.0	17.0	5.7
8	27-0060-3	13.0	22.2	6.6
9		Diameter (Ø) 3.05m		
10	30-0060-1	9.0	16.0	5.1
11	30-0060-2	13.0	22.5	6
12	30-0060-3	17.0	29.5	6.9
13		Diameter (Ø) 3.6m		
14	36-0060-1	13.0	21.70	5.1
15	36-0060-2	19.0	30.9	5.9
16	36-0060-3	25.0	40.1	6.8

»» Feeding Line loading capacity

item	75#	90#
Lift capacity	1400kg/h	2500kg/h
Maximum length	60m	40m
Drive motor	0.75kw	0.75/1.1kw
Feed tube diameter	75mm	90mm
Tube thickness	PVC/3.6mm	PVC/4mm
Bending radius	1750mm	2550mm
Dragon outer diameter	60mm	70mm

Broiler pan feeding system

Broiler automatic feeding system include driving device, hopper, conveying pipe, auger, pans, suspension lifting device, anti-perching device and feed sensor. The main function of the system is to transport the feed from the hopper into each feeding pan to ensure the eating of the broiler and automatically controlled by the level sensor's direction which give the order to motor to make it working or stop

»» Feeding Line specification:

SQ.	Pan Specification	
1	Diameter	330 mm
2	Material	PP (polypropylene)
3	Section	14 pcs
4	Feeding	40 ~ 50 chicken / pan
5	Adding antioxidants	purple agents, anti-aging
6	Movement degrees	360° rotation and swing freely, prevent chickens bruises
7	Switch	adjustable to regulate the feed discharging amount until close completely
8	feed volume	adjusted by the cover rotation, easy operate
9	Pipe	
10	Feed pipe	4-hole / 3 m, 3-hole three meters
11	Material	galvanized steel, galvanized thickness 275g / m2
12	Wall thickness	1.2 mm
13	Feeding capacity	450 Kg / h



Breeders feeding line

During breeder rearing period, uniformity is the most important indicators, to ensure adequate intake of chickens space is fundamental.

The breeder pans have 16 grill section which is 2 grill section than normal 14, which increasing the feeding area.

At the same time, the each meter takes 2 more chicken than the normal feeding trough line

The inside and outside the grid relatively movable within the range of 40 – 50mm, the width of the feeding section is adjusted by an external knob;

The height is adjustable into three positions: 45.5mm, 53.5mm, 63.0mm, with the growth of age, it can increase the high rim prevents chicken feed material plane.

High feed trough, which the height is 292mm, compared with trough feed line give more moving space for chicken, chicken are freely pass through it to nest and drinking line.



Feed level	Feed amount
3#	245g
4#	277g
5#	317g
6#	364g
7#	414g
8#	466g
9#	519g
10#	575g
11#	632g
12#	691g
13#	747g
14#	801g



Driving unit	Power	2.2kw		
	Speed	36m/min		
	Speed	>2T/h		
Feed trough	Trough length	3.6m	3.4m	3.2m
	Pan Qty.	4	4	4
	Pitch	900mm	850mm	800mm
Hopper capacity	Three model	48kg	280kg	350kg

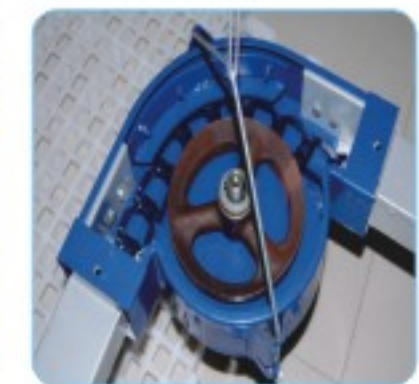

Chicken feed chain line

The driving device is cyclical pin wheel reducer, which working more stable, reliable, feeding averagely, low noise compare with gear reducer, the feeding speed can up to 36m/min.

The feed trough and connecting parts is elevating style, the height can be adjusted according to the different broiler life stage.

The rack material is high strength nylon which anti-corrosion, more suitable for the broiler house.

The surface of 90 digress corner wheel and guiding orbit have the special treatment of hardness, the bear is no need fill oil which material is alloy which anti. corrosion, and have the long working life.

The feed trough is made of anti-corrosion and rust steel, at the same time equipped with feed grill which size is 44mm, which effectively separate the cock from female breeders. The grill width is variable according to customer needs.

There is a plastic block sheet which stops the feed go outside of trough.

The feeding speed: 36m/min transmission speed is guarantee the rapid and uniform feed transmission, carrying capacity is 0.7-1.5kg/m, max. transport length is 260 meters.

Drive: the solid base and special material production ensure the normal and stable operation, in addition with safety pin device. Power : 1.5/2.2kw application material line length is 150-300m.

3 corner wheel: 90 degree high strength angle wheel, drive gear and corner wheel are made of wear resistant material, and after high frequency quenching, high hardness, wear resistance.

4 chain: South Africa champion brand chain, the world's best chain, high tensile strength, long service life.

5 material trough: material trough is 1.2mm thick hot galvanized sheet material, wear-resisting anti rust.

6: made of galvanized steel wire grid, grid spacing uniform, standard width is 42mm.

7. material box

Material box for hot galvanized sheet material, wear resistance. Each line is equipped with a large box of material and a small box, with dust cover, beautiful appearance, durable.

Large tank volume: 150kg

Small box volume: 250kg

8. bracket: stand type lifting, easy to adjust the height, save time and effort.

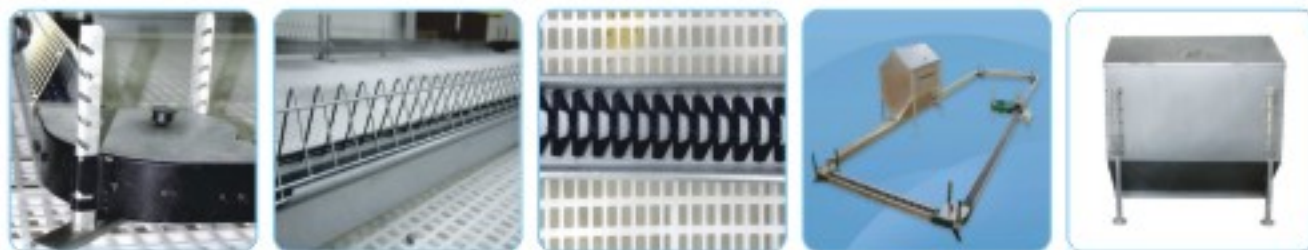

»» Environmental control system Fan

	Fan Diameter mm	Voltage V	Electric current A	Power W	Speed r/min	Exhaust air m3/h	Noise	Installation dimensions
24*Speed regulating fan	630	220	0.37	2.7	930	0~12000	<70	800*800*450
36*Suspension fan	910	380	0.4	1.6	1400	23000	<64	1000*1000*450
36*Box type air blower	910	380/220	0.4/0.55	1.6	1400	20800	<62	1000*1000*450
50*Box type air blower	1270	380/220	1.1/1.5	2.8	1440	43500	<62	1380*1380*450
50*Dual fan	1270	380	1.1	2.8	1440	46000	<65	1380*1380*450
50*Suspension fan	1270	380	1.1	2.8	1440	46000	<65	1380*1380*450
50*Cone fan	1270	380/220	1.1/1.5	2.8	1440	49380	<65	1380*1380*1180



»» Air Inlet:

Size: 620 x 225mm

Material: High quality polystyrene, embedded channel steel and stainless steel round pipe

Feature:

Easy installation

Main door mounded in two pieces preventing deformation

Main door has an insulated core, preventing condensation on inside

Adjustable flap allowing fine adjustment of air flow patterns

With stands cleaning with a high pressure cleaner

Control device

Automatic Winch

Auto winch works with the help of environment controller according to setting pressure of poultry house.

After receiving command, auto winch can pull inlet to change its opening angle.

In this way, automatically achieve the required working pressure setting of the bird house.

Light trap could also be installed.

Manual Winch

Operators watch the pressure meter in the house, and use and winch, until it reaches to the appropriate data.



»» Cooling pad

Huabo cooling pad is made of raw material, by sticking wave fiber paper. After integrating some special chemical composition and post-processing, the cooling pad is anti corrosive, high strength, and with long service life. It can supply enough surface area for heat exchange of the water and air and also can purify air as natural filter.

Technical data

Technical data of water pump

a. power: 0.6kw, flow rate: 7m³/h, lift: 13m

b. power: 0.8kw, flow rate: 7m³/h, lift: 20m

c. power: 1.1kw, flow rate: 30m³/h, lift: 10m

Cooling pad size

Cooling pads

	Dm790	Dm760
H (mm)	1500 ; 1800 ; 2000	1500 ; 1800 ; 2000
W (mm)	600	600
D (mm)	100 ; 150	100 ; 150
h (mm)	7	7
á	45	15
â	45	45

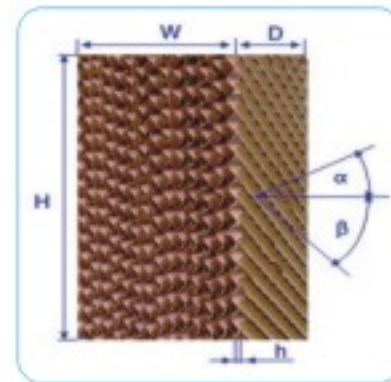

»» Light Trap

Type	Dimension
50 "Fan" s Lens hood	1400*1400*250mm
	1400*1400*200mm
36" Fan" s Lens hood	1000*1000*200mm
	1000*1000*200mm
Damper Lens hood	630*250*250mm
Shading wall	According to the chicken house

Customized sizes are acceptable.

Light trap sheets are made of high quality plastic. Reasonable double-wave shape make sure the shade performance, meanwhile reduce the air resistance.

Light trap are easily to be disassembled and cleaned.



»» Foggy system

Working principle

Atomizing cooling system works as per the principle that water can adjust the NATURE climate. Water will enter high pressure nozzle after purified by the filter and compressed by high-pressure pump then spray in atomization status(25-30 µm/granule). Atomizing granule fully mix with hot-air while following circulating wind, and absorb large amount of heat. At the same time, evaporated atomizing granule accelerate air flow. Temperature of the house will go down immediately thereby. In hot summer, if the temperature in the house is over 40°C, this system can lower the temperature by 3-8°C in a few minutes.

Main characters

Well-know brand motor with long life

Water source enter pump group after going through multi-filters with Honeycomb Type filter corn, at 50µm/hole.

There are three foggy lines in standard house, and each nozzle with two spraying hole every 3m to ensure spray into every corner.

Side pipe is anti-high pressure PE pipe and able to endure high pressure of 100kg, anti-corrosive.

Main pipe is made of anti high pressure copper tube, from which two ways are divided, to ensure homogeneous atomizing granule everywhere under identical spraying pressure.

Special copper nozzle, with flat stainless steel chips.

Cooling, Humidification, Dedusting and Disinfection

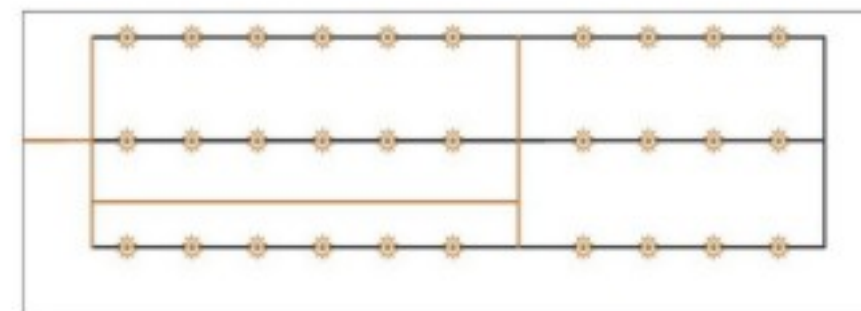

- Anti-high pressure PE pipe
- Copper tube
- ⊙ Copper orifice

»» Controller

ROTEM controller series

Fully automatic operation

Temperature curve: can be adjusted according to the age of day.

Precision ventilation: fan group, the precision of the ventilation level set, can be automatically adjusted according to age.

Ventilation and adjust the humidity humidifier

Coop: save fuel heating zone, temperature uniformity.

Water curtain control

Lighting and feed control

Chicken scales



LAN remote control computer, view the situation whenever and wherever possible.

Detailed historical records to facilitate the production analysis and summary.

Agrologic controller series

T616

5 temperature, 1 water, 1 negative pressure module (optional), 6 groups of fan, 1 group foggy system, 1 group cooling, 1 group alarm, 1 group heating, 1 group stock line, 1 group light, 1 group window, 1 group curtain, 2 sets of 0-10V output (with the external with the light, the wind machine frequency converter), including the temperature curve and weight gain curve.

T607A

Climate controllers reliable, user friendly micro controllers especially designed for broiler houses.

Has built 8 in relays for alarm output, heater, 5 groups of fan, cooling equipment.

LCD screen makes the computer and user communicate easily. User could input data to program the micro computer.

Several relays there. You could add relays to control more equipment.

Available to control heating, ventilation, cooling, air inlet.

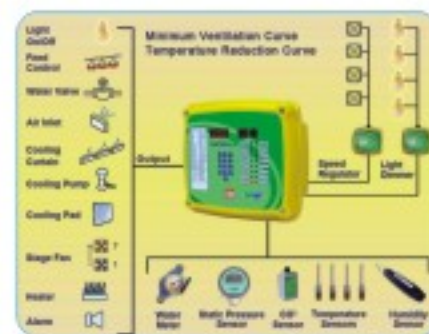

»» Slat Floor

New-type reinforced structure and material

Made of modified and purified raw plastics

High intensity and durability

Anti-corrosion

UV and anti-aging

Oxidation-resistance

Easy clean and installation

Long service life

Reasonable design of hole size can avoid the hurt of bird foot Self-regulating raising and lowering function to solve the problem of installation on the uneven ground.

Adjustable leg height range: 400mm-500mm (according to customer's requirement)

Beam is made of reinforced and anti-aging PVC material sturdy and durable, anti-rust and anti-corrosion.

Ingenious and all plastic adjustable leg structure.

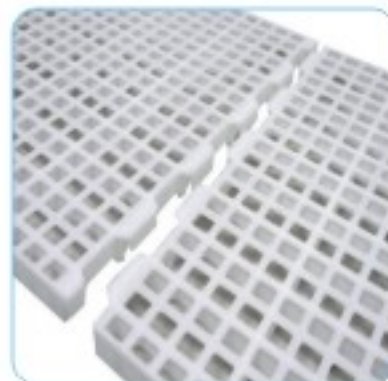
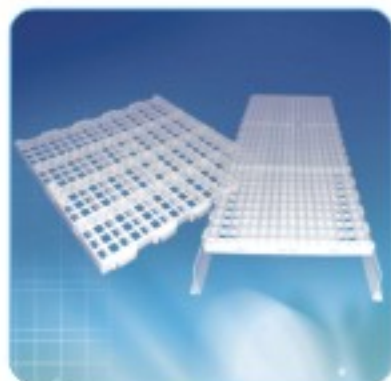

»» Hot Air Heater

The pullets raising is the key factor of broiler raising, which effect the whole broiler raising, which not only effect the live and growing rate, but also effect the final broiler production.

Re-heating is very important even in the summer which the house have to be pre-heating at least 24 to 48 hours before chicks put in. The flooring material temperature not less than 32°C (90°F), the air and inside house all the parts all well heated before chicks enter. The chicks movement and feed consumption are lower if can't reach to this temperature. If the chicks don't eat fast, its weight of chicken will lose the chance which the first week weight of chicks get 4 times of first day old chicks' weight. It is request to pre-heating the whole house including whole inside room building material, like flooring material, floor, building wall and purlin.

Features:

The fuel is diesel, rapid heating

Automatic working

Automatic temperature control



»» Model:

Model	DH-20	DH-40	T67	T115
Heating amount	23kw/H	43kw/H	66kw/H	115kw/H
	20000Cal/H	37000Cal/H	56700Cal/H	99100Cal/H
Hot Air Amount (m ³ /H)	400	1050	3000	5000
Motor power (w)	100	250	370	550
Fuel consumption (Liter/H)	1.8	3.5	6.07	10.6
Fuel tank volume (Liter)	21	42		
Voltage (Hz)	220	220	220	220
Weight(Kg)	26	37	83	130
Dimension(cm)	81x36x38	93x44x57	141x46x96	172x72x106

SINGLE-STAGE INCUBATOR

»» SINGLE-STAGE INCUBATOR WITH LARGE CAPACITY

Single-stage incubator with large capacity has large development potential now. It has large capacity and adopts the whole batch of hatching, the whole batch of finish hatching, which is a new generation of intelligent incubation equipment developed by our company.

The product has stable and uniform flow field and temperature field, remarkable effect on energy-saving and area-saving and a number of patented technologies. The appearance, structure, flow mode and control system of the product is in the leading level in the similar series products.



»» EIFTPC-60480

Single-stage incubator with large capacity

- Patent of invention: 200910017820.0
 - Patent of utility model: 200920031309.1
 - Patent of utility model: 200520087720.2
- For its unique water-cooling system which can narrow temperature gradient
- Gold award for Scientific and Technical Innovation on the tenth (2012) Animal Husbandry Exhibition

»» Technical specifications

- Egg capacity:
For chick: 40320/60480/80640/120960
For duck: 28800/34560/51840/69120
- Temp control range: 20°C~38.5°C
accurate temperature control range 34°C ~ 38.5°C
- Humidity control range: 40%~70%RH
- Temperature stability: <0.1°C
- Egg turning angle: 43±2°
- Apparent power: 5.9 KW to 27.6 KW
- Power supply: 380/220 VAC ± 10% (Three-phase five -wire system)

»» Highlights

- With state patented laminar airflow technology and narrowed temperature gradient water cooling designs, even and uniform temperature and airflow fields will be achieved, resulting in optimum chick quality and lower power consumption.
- Effective cooling: air cooling, Dual water cooling systems design makes it highly adaptive to the environment.
- Spray humidification delivers perfectly distributed humidity and makes bio-security easy.
- Touch-screen interface: facilitates visual simplicity in operation.
- Space saving: holds more eggs per m2, leading to less building costs.
- Practical functions: fumigation & exhaust, auto timing, variant temperature group setting and temperature calibration.
- With history data recording and analyzing function, you get useful curve diagrams.
- History data can be output into a USB flash disk.
- Option: Hatchery air handing system with energy-recycling technology (recycling both latent heat and sensible heat).
- Option: embryonic online weightlessness control system, carbon dioxide control system and embryonic temperature control system can make hatch so easy.



The touch display screen



B water cooling system



Fan heating



Humidification system

»» The main products specifications of single-stage incubator with large capacity

	Series&Model	Dimensions (W×L×H) mm	Capacity (Pcs)	Capacity		Trolley		Setter tray /Hatcher basket	Fan power (Kw)	Apparent power (Kw)
				qty	capacity	tier	size in mm			
Setter	EIFTPC-40320	5100×2770×2740	40320	8	5040	15	730×1290×2220	42	1.5	5.9/9.9
	EIFTPC-60480	6980×2770×2740	60480	12	5040	15	730×1290×2220	42	1.5	7.8/13.8
	EIFTPC-80640	5100×5460×2740	80640	16	5040	15	730×1290×2220	42	3	11.7/19.8
	EIFTPC-120960	6980×5460×2740	120960	24	5040	15	730×1290×2220	42	3	15.6/27.6
	EIFTPCII-60480	6280×2770×2670	60480	8	7560	15	1030×1290×2150	42	1.5	7.8/13.8
	EIFTPCII-120960	6280×5460×2670	120960	16	7560	15	1030×1290×2150	42	3	15.6/27.6
Duck	EIFTPC-Y28800	4740×3550×2770	28800	8	3600	12	685×1670×2220	30/60	1.8	6.0/10
	EIFTPC-Y34560	6280×2770×2670	34560	8	4320	12	1030×1290×2150	30/60	1.5	7.8/13.8
	EIFTPC-Y51840	5100×5460×2670	51840	12	4320	12	1030×1290×2150	30/60	3	12.8/19.8
Hatcher	EIFTPC-Y69120	6280×5460×2670	69120	16	4320	12	1030×1290×2150	30/60	3	15.6/27.6
	EICTPC-30240	4405×2770×2420	30240	6	5040	16	775×1317×236	168	1.5	6.3
	EICTPC-40320	5100×2770×2420	40320	8	5040	16	775×1317×236	168	1.5	6.3
	EICTPC-Y28800	5100×2770×2740	28800	8	3600	15	795×1290×2222	120	1.5	6.3
	EICTPC-Y17280	4210×2770×2450	17280	6	2880	13	775×1317×236	120	1.5	6.3
EICTPC-Y23040	5100×2770×2420	23040	8	2880	13	775×1317×236	120	1.5	6.3	

BOX-TYPE INCUBATOR



19200/16800



38400/57600

Technical specifications

- Temp control range: 34.2°C~39.5°C
- Humidity control range: 40%~70%RH
- Temp control precision: ±0.1°C
- Display resolution for temperature: 0.01°C
- Display resolution for humidity: 1%RH
- Stability of temperature field: ≤ 0.10°C
- CO2 content inside box during later period of incubating: <0.15%
- Egg-turning angle: 43°±2°
(For ducks: 50°±2°)

Main control system



Incubator intelligent control system with Chinese display



Incubator control system with multifunction display

The main structure

Host machine (fan system, egg turnover mechanism, air cooling system, humidification mechanism, damper system), box (top plate, side plate, back plate, door sheet and profile), control box (CPU main board, power board, relay board and strong electric control circuit, etc.), hatching trolleys (including trays and baskets).

Functional system

Agitating fan system, heating system, humidifying system, egg turnover system, air-cooling system, damper system, control system, also can equip with water warming/cooling system and group control system as needed.



Egg turnover mechanism



Egg turnover detection

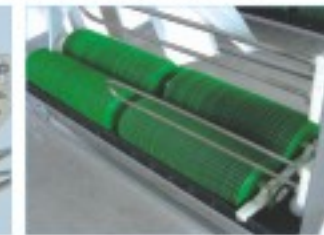

Humidifying mechanism



Agitating fan system



Temperature and humidity sensor



Air-cooling system



Damper system



Trolleys

The work environment

- Ambient temperature: 20 - 27 °C (The best state)
- Ambient humidity: 50 - 70% RH
- Power supply: three-phase five-wire system(three phase lines, center line and grounding line) 380 V / 220 VAC50Hz±10%, the special machine use single-phase, each machine's power line shall be equip with a separate control knife switch or air switch with reliable connection; there must be equip with earth leakage protective device in the power distribution system of hatchery, and the center line (zero line) must be with reliable connection and well grounded.
- Water pressure: 3 ~ 5 KgF/cm²
- Hatchery requirements: the ground roughness ≤ 5mm within 10 m² with drains. Height of the hatchery ≥ 4.5 m, with good ventilation. Exhaust gases from the incubation equipment exhaust through pipes to the outside.

The main products specifications of box-type incubator

Series	Model	Breed	Capacity (eggs)	Trolley qty × loaded egg qty	Dimensions (L*W*H)mm	Apparent power (Kw)
Setter	EIF (DZ/DMS/TPC) -19200	chick	19200	4 × 4800	3360 × 2235 × 2375	5.84
	EIF (DZ/DMS/TPC) -Y12096	duck	12096	4 × 3024	3360 × 2235 × 2375	5.84
	EIF (DZ/DMS/TPC) -S22528	yellow-feathered broilers	22528	4 × 5632	3360 × 2235 × 2375	5.84
	EIF (DZ/DMS/TPC) -E7680	goose	7680	4 × 1920	3360 × 2235 × 2375	5.84
	EIFDMS-38400	chick	38400	4 × 4800	3360 × 3860 × 2630	9.54
	EIFDMS-57600	chick	57600	12 × 4800	4500 × 3860 × 2630	10.54
Hatcher	EIC (DZ/DMS/TPC) -19200	chick	19200	4 × 4800	3360 × 2235 × 2375	5.66
	EIC (DZ/DMS/TPC) -Y12096	duck	12096	4 × 3024	3360 × 2235 × 2375	5.66
	EIC (DZ/DMS/TPC) -S22528	yellow-feathered broilers	22528	4 × 5632	3360 × 2235 × 2375	5.66
	EIC (DZ/DMS/TPC) -E7680	goose	7680	4 × 1920	3360 × 2235 × 2375	5.66

Multi-stage incubator

EI series multi-stage tunnel incubator is developed by our company taking own technical advantages, which leads breeding industry in our company to the direction of large-scale, standardization and intensive.

The three major advantages of equipment: energy saving, area saving and labor saving have greatly increased the production efficiency and cut the hatching cost of China's breeding industry.

»» EI HATCHING TUNNEL INCUBATOR



The touch display screen



Partition fan, heating and water cooling

»» The main features

- The left and right tunnels are partitioned by our patent technology different sections which are controlled separately.
- The heating and cooling of left and right tunnels are controlled separately. The temperature of major control points in the left and right tunnels can be set different or the same. The unique intelligent temperature adjustment technology makes the temperature in the left and right tunnels consistent.
- Heighten and widen the box size, having stronger adaptability for breeding eggs, which can incubate 50 ~ 82 g eggs.
- PT100 temperature sensors save calibration for temperature and humidity for a long time.
- WINDOWS interface with new graphical touch control makes the operation more simple and intuitive.
- EI remote monitoring management system which is based on the Internet.

EIFXDZ-V-90720 TUNNEL INCUBATOR

»» Technology index

- Egg capacity: 90720
- Quantity of egg trolleys: 12
- Temperature control range: 35 °C~39.00 °C
- Temperature control precision: 0.1 °C
- Humidity control range: 40~80%RH
- Humidity control precision $\pm 2\%$ RH
- Egg turnover angle: $43 \pm 2^\circ$
- Insulation resistance: $> 2 \text{ M}\Omega$
- Apparent power: 7.0 KW / 9.7 KW
- Power supply: 380/220 VAC $\pm 10\%$
(Three-phase five-wire system)

»» The main features

- **Fuzzy control technology:** Fuzzy control technology is using intelligent control to control the temperature of box, humidity, ventilation and turnover timing of breeding eggs which conforms to the development law of poultry embryo.
- **Intelligent thermoregulation:** Compared with the similar equipment both at home and abroad, intelligent temperature regulation technology applied to multi-stage incubation equipment is a major breakthrough in the control technology. Intelligent temperature regulation technology makes the machine inducts temperature change automatically, and then makes appropriate adjustment to the temperature parameters of the machine through the simulated experience. It can ensure that temperature within effective area in tunnel incubator meets needs of different ages of embryos, which can improve equipment performance, facilitate the production management in large and medium-sized hatchery, and effectively reduce artificial frequent temperature measurement and regulation.
- **Super energy-saving:** The capacity of tunnel incubator is large; Using the technics of incubation in batches, making full use of self-heating embryo generating in the later stage for new breeding eggs, and the unique trapezoid temperature field can greatly reduce the heating energy consumption.
- **Saving area:** Compared with the same capacity of box incubation, the area cover of a single egg is saved by 28% and the number of machines reduces by 80%, which greatly reduces construction investment and improves maintenance management efficiency.
- **Heat preservation:** using imported 44mm Dow Keith box board which is beautiful and anti-corrosion, and with the good heat preservation effect.



The control panel



Fan, heating and water cooling system

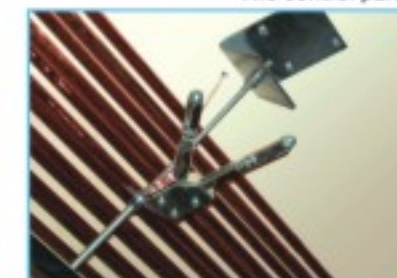

Humidifying nozzle and components



Egg trolley



Egg trolley curtain, air pipe and testing switch



The seal around egg trolley

CIRCULATING AIR FLOW HATCHER

Hatching is a very important procedure of the whole incubating process; design and work performance of hatching equipment directly influence quality of chicks. Traditional hatching equipments consume relatively larger amount of electricity, disinfect in complicated procedures, could result in poor healthy chick rate, has been important factor that influence chicks product quality. It has become consumers' common requests for hatchers' producers to resolve above problems. Based on concept of "do everything for consumers", XingYi company has invested qualified R&D source for years, after large amount of comparison experiments and arguments, introduced a new model of circulating air flow Hatcher. The circulating air flow Hatcher have realized two broken through in both design concept and work performance, resolved several difficult problems of traditional hatching equipments, won common trust and good comments from wide consumers.

Technical specifications

- Egg capacity: 15120
- Quantity of egg trolleys: 6
- Temp control range: 36°C-38°C
- Humidity control range: 40%-70%RH
- Temp control precision: ±0.1°C
- Humidity control precision: 2%RH
- Stability of temperature field: <0.10°C
- CO2 content during the later hatching insides Hatcher: <0.15%
- Apparent power: 4.64 KW
- Power supply: 380/220 VAC ±10%
(Three-phase five-wire system)



Main features

- Special "0" type air flow: Reasonable flow field design results in better inside air flow field and temperature field, facilitating development of embryo, thus gain better hatching result. Comparison from customers practice shows: hatching rate of circulating air flow Hatcher is averagely 1% higher than that of normal hatchers; with 2% higher hatching rate of A class chicks.
- Intelligent temperature adjustment: It means that Hatcher automatically sense change of temperature field inside box of the Hatcher, then simulate human experience, make proper adjustment on temperature. It will automatically decrease temperature setting value of major control point if temperature is high while it will automatically increase temperature setting value of major control point if temperature is low, resulting in a stable inside Hatcher temperature field. In addition to the major control temperature probe located at right side of the Hatcher, there is an intelligent temperature adjustment probe at the middle of circulating air flow Hatcher, making Hatcher control process more intelligent.
- High efficiency and energy saving: Circulating air flow Hatcher has excellent energy saving effect. Just taking rated power of fans as example, rated power of fans of normal hatchers is 1.5kw while rated power of total 3 fans' motors of circulating air flow is 0.54kw only.
- Super damper capability: Dampers of circulating air flow Hatcher have 22 positions, positions ranged from 0-21 of dampers reflect amount of air exchange ranged from small to larger, lifting Hatcher's adaptability to great extent.
- Spray humidifying with capability of epidemic prevention: Circulating air flow Hatcher adopts spraying humidifying, increasing humidifying capability of Hatcher and facilitating epidemic prevention.

THE MAIN PRODUCTS SPECIFICATIONS OF MULTI-STAGE INCUBATOR

Description	Model	Breed	Unit	Capacity (eggs)	Dimensions (L*W*H)mm	Setter trolley/Hatcher trolley (rack trolley) specifications			Tray/Hatcher basket specifications			Total power (Kw)	
						Qty	Tier	Capacity	Dimensions (L*W*H)mm	Capacity	Tier		Dimensions (L*W*H)mm
Setter	E1FXDZ-IV-90720		Set	90720/77760	8.34×3.12×2.56	12	15	7560/6480	1250×1000×2050	42/36	12	306×292×75/290×290×72	7.0/9.7
	E1FXDZ-V-90720 Subzone control	chick	Set	90720	8.34×3.12×2.56	12	15			42/36	12		5.6/7.6
	E1FXDT-HK-90720 Hatching Tunnel incubator		Set	90720	8.34×3.21×2.67	12	15	7560	1250×1030×2150	42	12	316×302×75	5.6/7.6
	E1FXDZ-Y37440	duck	Set	37440	6.34×3.12×2.56	8	13	4680	1250×1000×2050	30/60	12	302×292×88/578×292×88	7.0/9.7
	E1FXDZ-Y34560		Set	34560	6.34×3.12×2.67	8	12	4320	1250×1000×2050	30/60	12	302×292×88/578×292×88	7.0/9.7
Hatcher	E1CXDH-15120	chick	Set	15120	3.36×2.00×1.99	6	16	2520	1317×392×205	168	1	1035×380×120	4.64
	E1CXDZ-Y9360	duck	Set	9360	3.36×2.00×1.99	6	16	1560	1307×392×205	120	1	1037×392×205	4.64

Vaccine Incubation Equipment



Before vaccine incubation

Number	Model	Dimensions(Mm)	Capacity (Pcs)	Trolley		egg tray(Pcs)
				size in mm	qty	
1	E1FHDZ-YM19200	3360×2370×2375	19200	1172×833×2170	4	150
2	E1FHDZ-YM19440	3360×2610×2375	19440/22680	1000×970×2050	4	36/42
3	E1FHDZ-YM17280	3360×2370×2375	17280	1172×833×2170	4	72High temperature
4	E1FXDZ-YM90720	6000×4000×2580	90720	1000×1250×2055	12	42
5	E1FXDZ-YM68040	4880×4000×2580	68040	1000×1250×2055	9	42
6	E1FXDZ-YM77760	6000×4000×2580	77760	1000×1250×2055	12	36
7	E1FXDZ-YM58320	4880×4000×2580	58320	1000×1250×2055	9	36
8	E1FXDZ-YM84000	3122×10134×2680	84000	1172×833×2055	20	150

After vaccine incubation

Number	Model	Dimensions(Mm)	Capacity (Pcs)	Trolley		egg tray(Pcs)
				size in mm	qty	
1	E1FHDZ-YM19200	3360×2370×2375	19200	1172×833×2170	4	150
2	E1FHDZ-YM19440/22680	3360×2610×2375	19440/22680	1000×970×2050	4	36/42
3	E1FXDZ-YM48384	4200×2900×2580	48384	1300×600×2075	8	42
4	E1FXDZ-YM60480	4200×3500×2580	60480	1620×600×2075	8	42
5	E1FXDZ-YM41472	4200×2900×2580	41472	1300×600×2075	8	36
6	E1FXDZ-YM51840	4200×3500×2580	51840	1620×600×2075	8	36

Whole vaccine procedure incubation

Number	Model	Dimensions(Mm)	Capacity (Pcs)	Trolley		egg tray(Pcs)
				size in mm	qty	
1	E1FTPC-1500	1270x1450x2050	1500	850x570x1561	1	150

HATCHERY AUTOMATION EQUIPMENT

Currently, hatchery automation equipment has become an indispensable part of modern production. The young chicks processing including hatching baskets transferring, young chicks and eggshell separation, hatching baskets cleaning, eggshell processing, counting and packaging mainly rely on manual operation, so the large labor intensity, low work efficiency and poor biological security problem restricts the development of breeding enterprises. With labor costs increasing year by year, the domestic large and medium sized breeding enterprises are eager to use the equipment to replace manual operation.

As the domestic largest research, development and production base of incubation and breeding equipment, EI electronics has held absolute leader position, thanks to our technology accumulation, in-depth study of material handling knowledge as well as the ascension of hatchery project comprehensive supporting ability. Our R & D department has been provided the domestic large and medium-sized hatchery with automatic, intelligent, high reliability of hatchery automation equipment including machine for candling & transferring, young chicks processing equipment and hatching basket cleaning equipment etc.

Main products**»» MACHINE FOR CANDLING & TRANSFERRING**

Automatic machine for candling & transferring with high-speed

Semi-automatic machine for candling & transferring

»» CHICKS PROCESSING EQUIPMENT

Transferring & Loading unit

Turnover & separation unit

Villi and broken eggshells adsorption unit

The gender identifying unit

Counting and packing unit

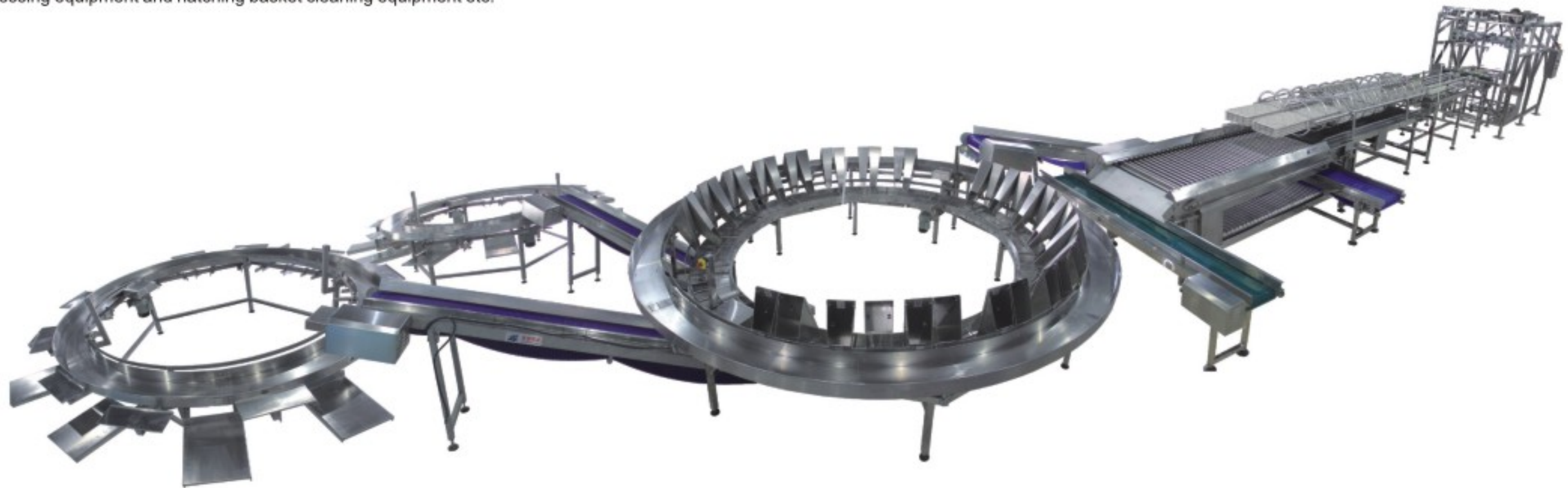
»» WASHING MACHINE**»» OTHER PRODUCTS**

CANDLING & TRANSFERRING EQUIPMENT

The equipment unloads egg trays in the trolley onto the conveyor, identifying live embryo eggs, unfertilized eggs and dead embryo eggs through the egg candling unit, and then transfer kinds of breeding eggs to hatching basket or corresponding conveyors. The equipment can be divided into: "Automatic candling & transferring equipment" and "Semi-automatic candling & transferring equipment". Users can choose suitable products according to your production scale.

»» AUTOMATIC MACHINE FOR CANDLING & TRANSFERRING WITH HIGH-SPEED

The equipment adopts advanced digital processing technology to identify the breeding eggs, the speed of candling & transferring is 50000 pieces per hour, applying to the standard tray for placing 42 eggs; It can accurately identify live embryo eggs, unfertilized eggs, dead embryo egg before 13 days, which is mainly used for candling & transferring 18 days of breeding eggs in large and medium-sized hatchery.



»» Technical parameter

- Working voltage: the three-phase five wire system 380 VAC/50 Hz
- Power: 7 KW
- Gas consumption: 300 litres/minute
- Overall dimensions: 8 x 3.5 x 2.2 m (the layout, the length and the width can be adjusted according to the room)
- Apply to the tray for placing 42 eggs with 75 g
- Work air source: 0.8 MPa
- Processing speed: 50000 pcs/ hour

»» The main features

- Calculate automatically the total quantity and percentage of live embryo eggs, unfertilized eggs and dead embryo eggs.
- Under the highest speed, 200,000 eggs completed with six people at four hours, and the work process without emotional and environmental impacts.
- 10-inch touch screen animation display, intuitive and clear, easy query historical data.
- Scalable to equipments of taking out trays, arranging trays, cleaning trays automatically in the front and back of the equipment.
- The operator is out of touch breeding eggs in the candling process, to avoid cross-contamination.
- The eggs sucker can be cleaned on-line without disassembly.
- The equipment frame adopts 304 stainless steel, elegant appearance, easy to clean, strong corrosion resistance.
- Regularly remind the maintenance.



Touch screen of the automatic machine for candling & transferring



SEMI-AUTOMATIC MACHINE FOR CANDLING & TRANSFERRING

Semi-automatic machine for candling & transferring adopts the whole tray candling technology and identifies breeding eggs with artificial recognition. The speed is 40000 eggs per hour and applicable to a variety of egg tray for chicks and ducks. The equipment operation is simple; it can reduce the labor intensity, increase candling efficiency by about 30%, and effectively reduce the damage rate of breeding eggs.

»» Equipment composition

mainly consists of: egg tray conveying line, swing arm fall tray manipulator, the whole tray candling light source, hatching basket platform and electrical control cabinet.

»» Technical parameter

- Falling speed: 40000 / hour
- Work air source: 0.8 MPa
- Gas consumption : 170 cube/hour
- Apparent power : 2.5KW
- Working voltage : the three-phase five wire system 380 VAC/50 Hz
- Overall dimensions : 3.5×2×1.8 (meter)

»» The main features

- The whole tray candling and falling
- Operators identify the unfertilized eggs and dead embryo eggs
- The tray falling with swing arm manipulator, reduce labor intensity.
- Scalable to equipments of taking out trays, arranging trays, cleaning trays automatically in the front and back of the equipment.
- The equipment frame adopts 304 stainless steel, elegant appearance, easy to clean, strong corrosion resistance.



CHICKS PROCESSING EQUIPMENT

The breeding industry developed fast in industrialization and large-scale today; the hatchery automation assembly line has a broad market prospect. EI chicks processing realized the whole line automation. Operators only need to pull the trolleys, greatly reduce the labor cost, has obvious advantages in market competition, and breakthrough the bottleneck of the industry development.

The transferring & loading unit, turnover & separation unit, gender identifying unit and immune platform, villi and broken eggshells adsorption, counting and packing unit, and baskets washing machine combined realize the automatic grab and dump of baskets, automatic separation of chicks and eggshells, broken eggshells adsorption, chicks short-distance transport, gender identification, immune, healthy chicks selection, counting and packing, baskets cleaning and so on, which have already achieved the total automation of hatching and reach the international advanced level.

»» Front-end equipment for chicks processing

transferring & Loading unit mechanically transferred hatching basket in Hatcher to Turnover & separation unit assembly line. Turnover & separation unit automatically empties hatching basket, and separates young chicks and eggshell. The seamless connection of these three modules forms the front-end equipment of young chick's treatment, the control units are very high degree of automation.

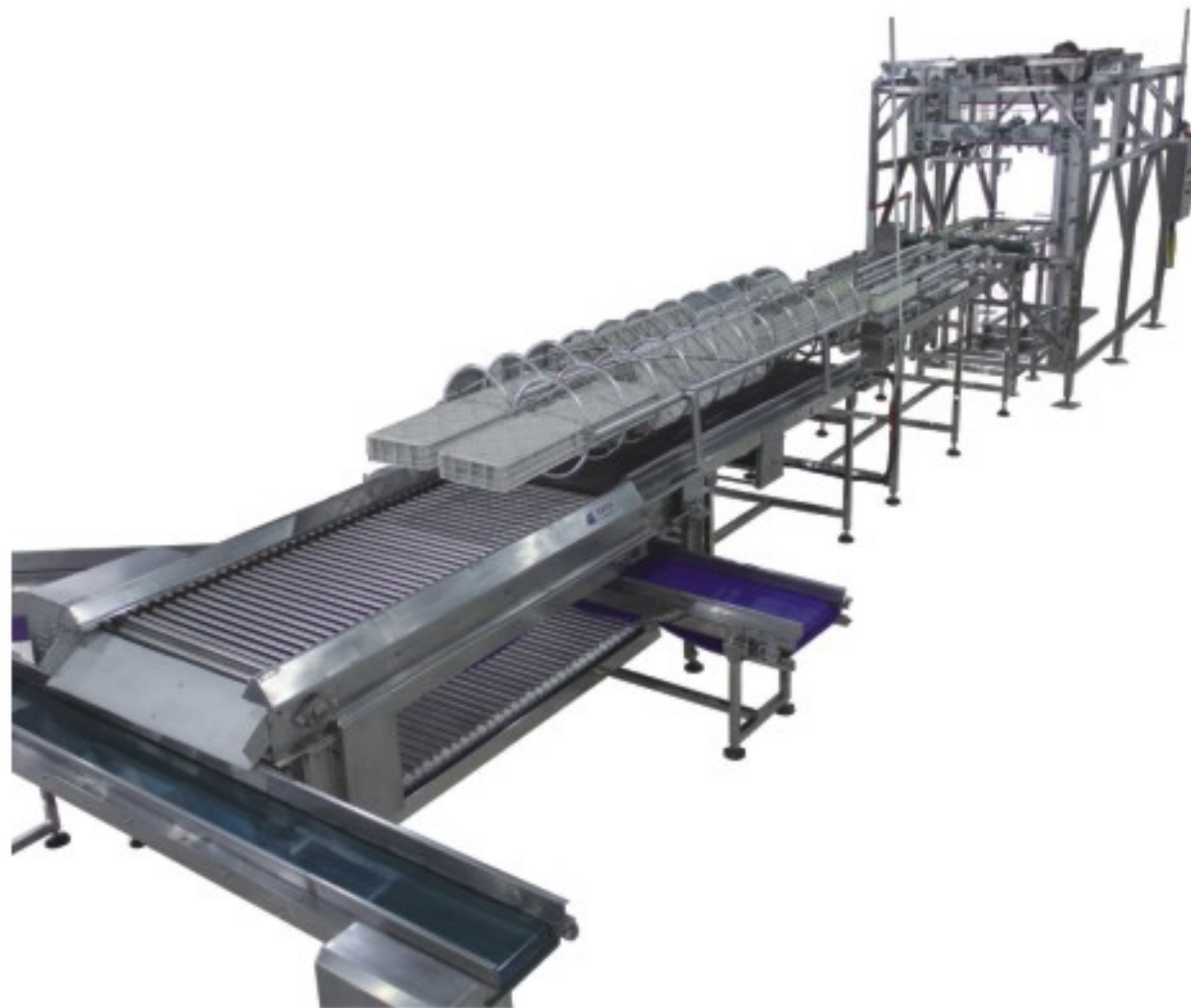

»» Work procedure

Operators pull out two hatching trolley from Hatcher, push into positioning device of Transferring & Loading unit, press the start button, the system automatically transfer two-columns hatching basket with three-layers to roller table line after detecting the hatching trolley, hatching basket mechanism push baskets into the keel chain conveyor at three times. Baskets emptied automatically after going turnover mechanism, empty hatching basket are delivered in hatching basket washing machine for cleaning and disinfection. Young chicks and the egg shell dumping on the conveyor belt are separated in the roller separation unit, and egg shell and unhatched egg are centralized processing delivered into the garbage disposal room by conveyor, young chicks be delivered to the next station through chain conveyor for selecting, gender identification, injection and immunization, counting, and packing and so on.

»» main features

- The front-end line of young chicks handles with 60000 chicks per hour, greatly improve production efficiency, and reduce the workers labor intensity.
- Thoroughly improve working conditions for workers.
- Reduce the direct contact with the man and the young chicks, avoid the pollution and cross infection, and improve the biosecurity standards.



Transferring & Loading unit



Turnover unit



Separation unit

»» VILLI AND BROKEN EGGSHELLS ADSORPTION UNIT

mainly consists of: cyclone dust removal equipment, pneumatic conveying equipment, feed tank and filter, etc.

»» Main features

- Cyclone dust removal equipment will remove small eggshell on net chain conveyor and achieve the complete separation.
- Pneumatic conveying equipment put these small and big eggshells together into the feed tank.
- Adsorb the villi in the air, reduce the fibrous villi content, and make villi content in the hatchery according with international standard.



BROKEN EGGSHELLS ADSORPTION UNIT

»» THE GENDER IDENTIFYING UNIT

The gender identifying unit mainly includes: gender identification rotary, immune and counting rotary, unhealthy chicks selection rotary, etc. The most important is gender identification unit, which is the working platform for gender identification in the chick process.



Gender identify turntable with 20 work positions (5.6 meters in diameter)



Injection immune turntable with 10 work positions (3.3 meters in diameter), with pneumatic syringe

»» Gender identification rotary

The gender identification rotary is suitable to identify the feather growth, feather color and anal anus of day old chicks. According to the diameter of the rotary, 6~20 identify positions could be provided. Every identify position has two funnels. With the movement of the rotary, the chicks are put in the corresponding funnel. Different gender chicks in the working positions are converged to the corresponding motor carrier, and sent to the next working positions.

»» Vaccine injection rotary

The vaccine injection rotary is suitable to inject vaccine for day old chicken. It can provide 6~20 vaccine injection working positions, which could be configured with air-powered injectors or single channel high-precision counter equipments.

»» CHICKS COUNTING AND PACKAGING UNIT

Mainly consists of: picking up work table, young chicks conveyor, counting conveyor, and U-shaped keel chain chicks box conveyor.



»» Main features

- **High counting efficiency:** the counting ability can reach more than 30000 chicks per hour.
- **More accurate counting and packing:** the counting accuracy is about 0.3%. People will become fatigue with the extension of the labor time, so the artificial counting is uncertain, thus affecting the counting accuracy.
- **Apply to various hatching basket:** the 95% hatching basket in domestic in the current (including plastic crate and carton) can be used in this equipment.
- **No damage to chicks:** It avoids the obvious and potential damage factors in the structural design of the equipment. The running speed of conveyor can not only ensure counting efficiency, but also can ensure the chicks safety effectively.
- **Software adaptability:** the control software of the equipment can correct key parameters automatically according to the length of chicks, making the system keep accuracy in any conditions.
- **Concise and reasonable man-machine interface:** the quantity of each basket can be set, and show the chicks quantity of current basket and total box number.
- **More scientific epidemic prevention:** greatly reduce the chance of workers contact chicks directly in hatching workshop, having a very positive meaning to prevent cross infection between people and chicks.
- **Anticorrosive and easy to wash:** The metal material of the complete equipment use the high quality stainless steel, the protection level of electrical components needing flush in above IP65, which is safe and reliable.



Counting and packing unit with two-paths



Counting unit

POULTRY FEED PROCESSING EQUIPMENT



STEEL FABRICATED HOUSE

CONNECT supply the complete steel structure and wall material for slaughterhouse building, farm building, rendering plant and hatchery building. The design of building is following the Standard building rules, which consider the full aspects of structure aesthetics, strength and practicability.



FREEZING EQUIPMENT

CONNECT supply the slaughterhouse cooling and meat storage solution for working conditions and products storage. Including the various working room cooling request, and blast freezer, chilling and cold storage for various production. We have one manufacture base plant company for sandwich panel and freezing equipment assemble plant for compressor and condenser, The compressor all use best brand in the word of Bitzer, the various gauges all from Italy, The condenser is the best brand in China.



CATTLE&SHEEP SLAUGHTERING EQUIPMENT

CONNECT supply the animal processing equipment including cattle, sheep processing system, All follows European Standard.



CONNECT GROUP GLOBAL MARKET DISTRIBUTION NETWORK

